

NGEN STAR 2900/4300/4800 BATTERY INSTALLATION MANUAL

Table of Contents

1.	Introduction	3
2.	Symbols.....	3
3.	Safety	4
3.1.	Handling	4
3.2.	Installation	4
4.	Response to Emergency Situations	5
5.	Product Information	6
5.1.	NGEN STAR Battery 2900 Specifications.....	6
5.2.	NGEN STAR Battery 4300 Specifications.....	7
5.3.	NGEN STAR Battery 4800 Specifications.....	8
6.	Product Features	9
6.1.	Battery System Features	9
7.	Installation	10
7.1.	Scope of Delivery	10
7.2.	Space Requirements	11
7.3	Required Tools.....	11
7.3.	Installation Steps.....	12
7.4.	Wiring Steps	15
7.5.	System Startup.....	16
8.	Commissioning.....	17
9.	Exclusion	18
10.	Troubleshooting and Maintenance.....	19
10.1.	Maintenance	19
10.2.	Troubleshooting.....	19

ENGLISH

Read the instruction carefully before installation. Failure to do so may result in personal injury and damage to property or invalidate the warranty and product guarantee. Installation requires specialist knowledge and may therefore only be carried out by appropriately qualified and authorized specialists!







The general handling of the product, its use or the exact installation methods are beyond the control of NGEN. Therefore, NGEN cannot accept any responsibility for damages, losses or cost resulting from improper installation, improper handling of the incorrect use!



1. Introduction

The document describes the installation, commissioning, maintenance and troubleshooting of the NGEN high voltage batteries: NGEN STAR 2900 NGEN STAR 4300 NGEN STAR 4800

The battery chemistry of these products is Lithium Iron Phosphate (LiFePO4). This manual is designed for qualified personnel only. These tasks described in this document should be performed by authorized and qualified technicians only. After the Installation the Installer must explain the user manual to the end user.

2. Symbols

	Symbol Explanation CE mark. The Battery complies with the requirements of the applicable CE guidelines.
	Attention, risk of electronic shock
	Do not place or install near flammable or explosive materials.
	Install the product out of reach of children.
	Read the instruction manual before starting installation and operation.
	Do not dispose of the products with household wastes.
	Disconnect the equipment before carrying out maintenance or repair.

	Observe precautions for handling electrostatic discharge sensitive devices.
	Protective conductor connection
	Attention, risk of electric shock, energy storage timed discharge.

3. Safety

Any work on the Batteries should be handled by authorized technicians and hence it is understood that the technicians should familiarize themselves with the contents of this manual before any maintenance or installation is carried out on the system.

3.1. Handling

- Do not expose battery to open flame.
- Do not place the product under direct sunlight.
- Do not place the product near flammable materials. It may lead to fire or explosion in case of accident.
- Store in a cool and dry place with ample ventilation.
- Do not store the product near water sources.
- Store the product on a flat surface.
- Store the product out of reach of children and animals.
- Do not damage the unit by dropping, deforming, impacting, cutting or penetrating with a sharp object. It may cause leakage of electrolyte or fire.
- Do not touch any liquid spilled out of the product. There is a risk of electric shock or damage to skin.
- Always handle the battery wearing the insulated gloves.
- Do not step on the product or place any foreign objects on it. This can result in damage.
- Do not charge or discharge damaged battery.

3.2. Installation

- Do not connect the NGEN-Star battery to the conductors of the inverter or the photovoltaic system. This will damage the battery and may lead to an explosion.
- Check the product for damage and missing parts after unpacking.
- Make sure that the inverter and the battery are completely switched off before starting the installation.
- Do not reverse the positive and negative poles of the battery.
- Ensure that there is no short circuit between the terminals or with an external device.
- Do not exceed the permissible battery voltage of the inverter.
- Do not connect the battery to an incompatible inverter.
- Do not connect different battery types together.

- Ensure that all batteries are properly earthed.
- Do not open the battery to repair or dismantle it. Such repairs may only be carried out by the manufacturer.
- Only use dry powder fire extinguishers in case of fire. Liquid fire extinguishers must not be used.
- Only install the batteries in an approved building. Installing the battery outdoors is not recommended.
- Do not install the battery near water sources or in places where the battery may get wet.
- Do not install the battery near children or pets.
- Do not use the battery in environments with a high static charge where the protective device could be damaged.

4. Response to Emergency Situations

The batteries consist of several batteries connected in series. They are designed to prevent hazards or failures. However, their absolute safety cannot be guaranteed.

- In case of contact with the internal materials of the battery, the user should follow the recommendations below.
- In case of inhalation, leave the contaminated area immediately and seek medical attention.
- In case of contact with eyes, rinse eyes with running water for 15 minutes and seek medical attention immediately.
- In case of contact with skin, wash affected area thoroughly with soap and seek medical advice immediately.
- If swallowed, induce vomiting, and seek medical attention.

Fire Situation

In situations where the battery is on fire, if it is safe to do so, switch off the battery by turning off the circuit breaker to disconnect the power supply to the system. Use an FM-200 or Co2 fire extinguisher for the battery and an ABC fire extinguisher for the other parts of the system.





In any fire situation, please evacuate people from the building immediately before attempting to extinguish the fire.

Water Situation





The battery modules are not waterproof. Therefore, make sure that they do not get wet. If the battery is fully or partially submerged in water, do not attempt to open it. Contact authorized personnel or NGEN for further instructions.

5. Product Information







5.1. NGEN STAR Battery 2900 Specifications

Specifications for NGEN STAR Battery 2900					
Model	S3	S4	S5	S6	S7
Technical Properties					
Battery designation*	IFpP42/151/108 /[(18S)3S]E/- 10+50/90	IFpP42/151/108/[(18S)4S]E/- 10+50/90	IFpP42/151/108/[(18S)5S]E/- 10+50/90	IFpP42/151/108/[(18S)6S]E/- 10+50/90	IFpP42/151/108/[(18S)7S]E/- 10+50/90
Number of batteries	1x Master 2x Slave	1x Master 3x Slave	1x Master 4x Slave	1x Master 5x Slave	1x Master 6x Slave
Nominal Voltage [V]	172,8	230,4	288	345,6	403,2
Nominal Capacity [Ah]	50	50	50	50	50
Nominal Energy [kWh]	8,64	11,52	14,4	17,28	20,16
Battery voltage range [V]	145,8-197,1	194,4-262,8	243-328,5	291,6-394,2	340,2-459,9
Max. Charge-/ Discharge Current [A]	50/50				
(CC-CV) Standard charging current [A]	25				
Constant current and constant voltage charging cut-off current [A]	2,5				
Peak discharge Current (60s) [A]	65				
Storage Temperature [°C]	-20°C ~55				
Operating Temperature range [°C]	Charge: 0°C ~55 Discharge: -10°C ~55				
Discharge Capacity [Ah]	35@-20±2°C @1C 50@25±2°C @0,5C 47@55±2°C @0,5C				
Cycle Life	≥ 6000 @25°C @ 70% SOH				
Ingress-Protection	IP65				
Protective Class	Class I				
Dimensions (L x W x H) [mm]	570x380x470	570x380x590	570x380x710	570x805x830	570x380x950
Weight [Kg]	102,9	134,7	166,5	198,3	230,1
Communication Interfaces	CAN				

5.2. NGEN STAR Battery 4300 Specifications

Specifications for NGEN STAR Battery 4300					
Model	S3	S4	S5	S6	S7
Technical Properties					
Battery designation	IFpP42/151/108/[(18S)3S]E/- 10+50/90	IFpP42/151/108/[(18S)4S]E/- 10+50/90	IFpP42/151/108/[(18S)5S]E/- 10+50/90	IFpP42/151/108/[(18S)6S]E/- 10+50/90	IFpP42/151/108/[(18S)7S]E/- 10+50/90
The number of batteries	1x Master 2x Slave	1x Master 3x Slave	1x Master 4x Slave	1x Master 5x Slave	1x Master 6x Slave
Nominal Voltage [V]	172,8	230,4	288	345,6	403,2
Nominal Capacity [Ah]	72	72	72	72	72
Nominal Energy [kWh]	12,44	16,59	20,74	24,88	29,03
Battery voltage range [V]	145,8-197,1	194,4-262,8	243-328,5	291,6-394,2	340,2-459,9
Max. Charge-/ Discharge Current [A]	50/50				
(CC-CV) Standard charging current [A]	35				
Constant current and constant voltage charging cut-off current [A]	3,5				
Peak discharge Current (60s) [A]	65				
Storage Temperature [°C]	-20°C ~55				
Operating Temperature range [°C]	Charge: 0°C ~55 Discharge: -10°C ~55				
Discharge Capacity [Ah]	57@-20±2°C @1C 72@25±2°C @0,5C 72@55±2°C @0,5C				
Cycle Life	≥ 6000 @25°C @ 70% SOH				
Protection Degree	IP65				
Protective Class	Class I				
Dimensions (L x W x H) [mm]	570x380x494	570x380x622	570x380x750	570x805x878	570x380x1006
Weight [Kg]	115.5	152.5	189.5	226.5	263.5
Communication Interfaces	CAN				
Certificates	IEC 62619; IEC 61000-6-1/2/3/4 ; UN38.3				

5.3. NGEN STAR Battery 4800 Specifications

Specifications for NGEN STAR Battery 4800							
Model	S3	S4	S5	S6	S7	S8	S9
Technical Properties							
Battery designation	IFpP42/151/108/[(18S)3S]E/-10+50/90	IFpP42/151/108/[(18S)4S]E/-10+50/90	IFpP42/151/108/[(18S)5S]E/-10+50/90	IFpP42/151/108/[(18S)6S]E/-10+50/90	IFpP42/151/108/[(18S)7S]E/-10+50/90	IFpP42/151/108/[(18S)8S]E/-10+50/90	IFpP42/151/108/[(18S)9S]E/-10+50/90
The number of batteries	1x Master 2x Slave	1x Master 3x Slave	1x Master 4x Slave	1x Master 5x Slave	1x Master 6x Slave	1x Master 7x Slave	1x Master 8x Slave
Nominal Voltage [V]	134,4	179,2	224	268,8	313,6	358,4	403,2
Nominal Capacity [Ah]	104	104	104	104	104	104	104
Nominal Energy [kWh]	13,98	18,64	23,3	27,96	32,61	37,27	41,93
Battery voltage range [V]	121,8 – 154,5	162,4 – 206,0	203,0 – 257,6	243,6 – 309,1	284,2 – 360,6	324,8 – 412,2	365,4 – 463,7
Max. Charge-/ Discharge Current [A]	50/50						
(CC-CV) Standard charging current [A]	30						
Constant current and constant voltage charging cut-off current [A]	3,5						
Peak discharge Current (60s) [A]	65						
Storage Temperature [°C]	-10°C ~35						
Operating Temperature range [°C]	Charge: 0°C ~55 Discharge: -10°C ~55						
Discharge Capacity [Ah]	57@-20±2°C @1C 72@25±2°C @0,5C 72@55±2°C @0,5C						
Cycle Life	≥ 6000						
Protection Degree	IP65						
Protective Class	Class I						
Dimensions (L x W x H) [mm]	570x524x380	570x662x380	570x800x380	570x938x380	570x1076x380	570x1214x380	570x1352x380
Weight [Kg]	122,5	161,5	200,5	239,5	278,5	317,5	356,5
Communication Interfaces	CAN						
Certificates	IEC 62619 ; IEC 61000-6-1/2/3/4 ; UN38.3						

6. Product Features

6.1. Battery System Features

The batteries are equipped with several protection systems to ensure the safe operation of the system. The protection systems include:

- Inverter interface protection: Overvoltage, overcurrent, external short circuit, reverse polarity, ground fault, overtemperature, overcurrent
- Battery protection: internal short circuit, overvoltage, overcurrent, overtemperature, undervoltage

The battery system has the following interfaces so that it can be connected and operated efficiently.

NGEN STAR Master-Unit Features:

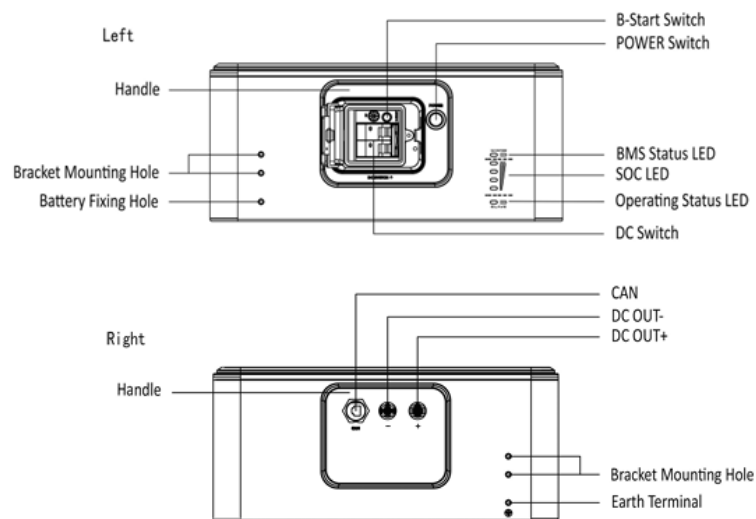

DC-Switch

Main Switch, battery charge and discharge circuit switch.

DC-Output +

Connect this output to Bat + of the inverter.

DC-Output -

Connect this output to Bat – of the inverter.

POWER-Switch

Switch to turn on the system, press this switch to start the system.

B-Switch (Blackstart)

Use this switch if there is no PV or mains connection. And it must be used when the battery is discharged.

DIP-Switch

The BMS relies on the DIP switches to confirm the number of NGEN STAR Batteries in the system. (Setting: master + slave modules minus 2)

BMS-Status-LED and SOC-LED

The LEDs display specific alarm information and the performance of the battery system

Operating Status LED

This LED is used to indicate if the battery is working effectively. A green light on this LED means that the battery is switched on and working normally. If the battery is not working properly, a red light on this LED means that the battery is operating abnormally. (see illustration on page 17 and 18)

NGEN Star Slave-Unit-Features

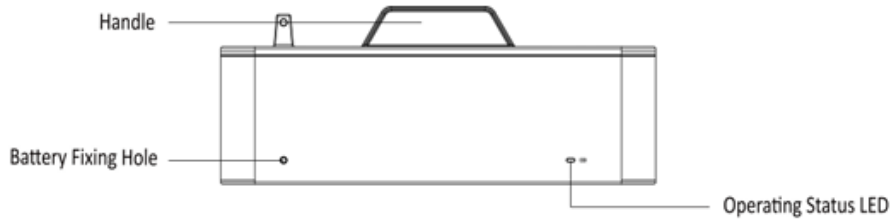

7. Installation

7.1. Scope of Delivery

For NGEN STAR Slave-Unit



Position	Item
A	Fixing screws
B	Installation instructions

For NGEN STAR Master-Unit

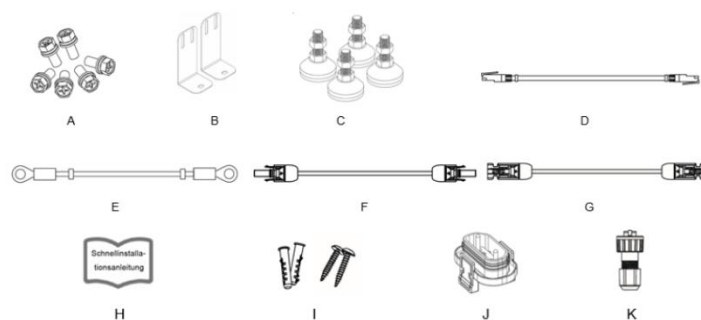

A	Fixing screws	G	Battery cable - (3m)
B	Wall bracket	H	Installation instructions
C	Foot supports (4 pieces)	I	Dowels & screws
D	Communication cable (3m)	J	Cover for the serial connection of the batteries
E	Earthing cable (3m)	K	K RJ45 plug
F	Battery cable + (3m)		

7.2. Space Requirements

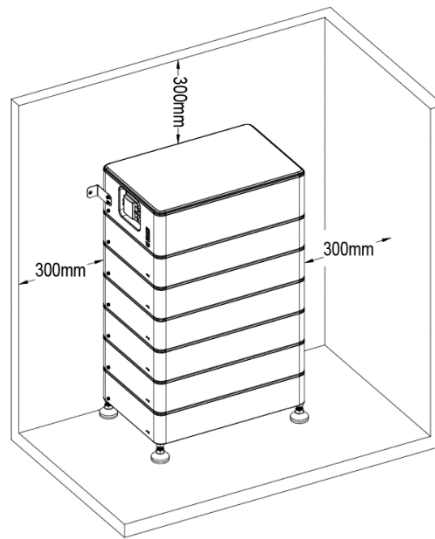

A clearance of at least 300 mm must be maintained around the battery pack to ensure cooling.

Attention: Ensure that the battery is installed in a room with adequate ventilation. The battery is cooled by natural convection. If the battery pack is completely or partially covered or shielded, this may result in the battery pack no longer functioning.

7.3 Required Tools

The following tools are required for the installation of the NGEN STAR Battery:



Screwdriver



Crimping tool



Safety Shoes



Multimeter



Safety Gloves



Safety Goggles



Plier



Cable Ties



Electric Drill



Spirit Level



Tape



Marker

7.3. Installation Steps

Step 1:

Install a NGEN STAR Slave-Unit with four footrests, which are included in the master unit. Place the slave on the floor and adjust it to the different floor heights. After installing the footrests, use a spirit level to check the levelling. Insert the waterproof cover into the bottom slave unit.

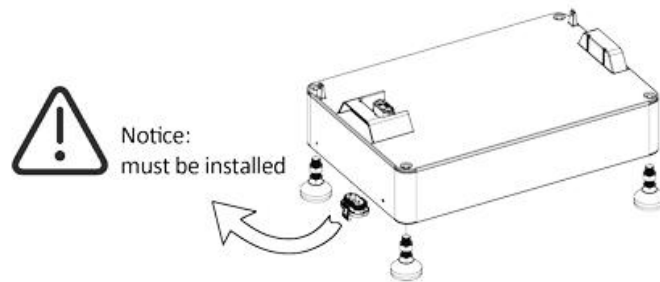

Step 2:

Place the battery 20 mm away from the Wall.

Note: Make sure that the operating status LED is on the left-hand side when viewing the battery model.

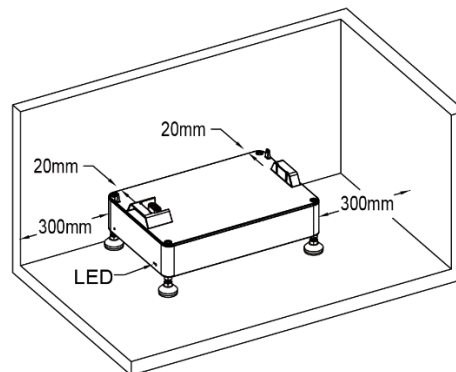

Step 3:

Stack the batteries one by one, making sure that the individual modules engage gently.

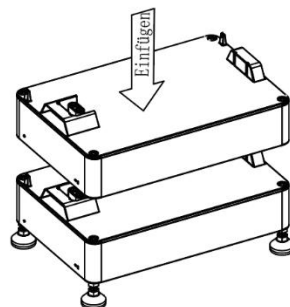

Step 4:

Attach the two mounting brackets to the left and right of the battery. The battery is attached to the wall with this mounting bracket.

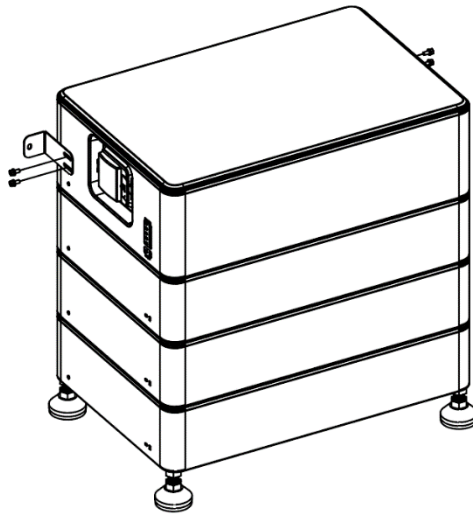

Step 5:

Mark the fixing holes on the wall.

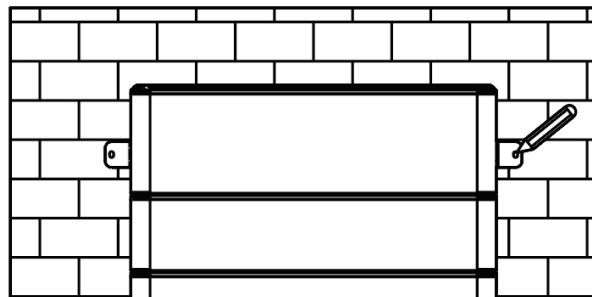

Step 6:

Only drill after you have removed the NGEN STAR Master-Unit. Drill the holes with an electric drill, make sure that the holes are at least 50 mm deep and that the dowels are fitted correctly.

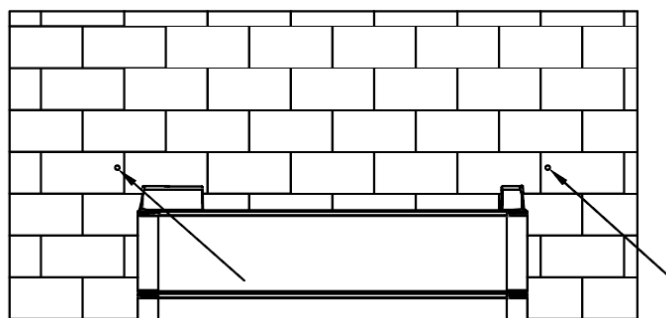

Step 7:

Once you have refitted the NGEN STAR Master-Unit, attach the battery to the wall.

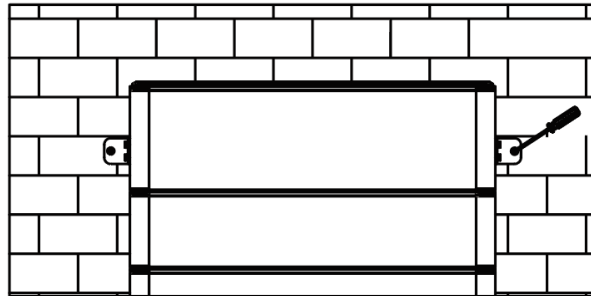

Step 8:

Fasten the safety screws on both sides of the battery.

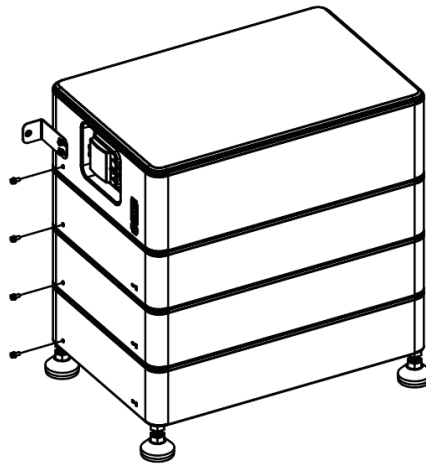

Note: Please ensure that each 3-phase system consists of 1x NGEN-Star master unit and at least 2x NGEN-Star slave units. For single-phase systems, 1x NGEN-Star master unit and at least 1x NGEN-Star slave unit is required.

7.4. Wiring Steps

Step 1:

Connect the power cable to the DC connectors of the NGEN STAR Master-Unit. The DC+ must be connected to the Master+ and the DC- to the Master- connector.

Step2:

Push the connectors until they are locked with a „Click“sound.

Note: For the wiring of the inverter, please refer to the user manual of the inverter.

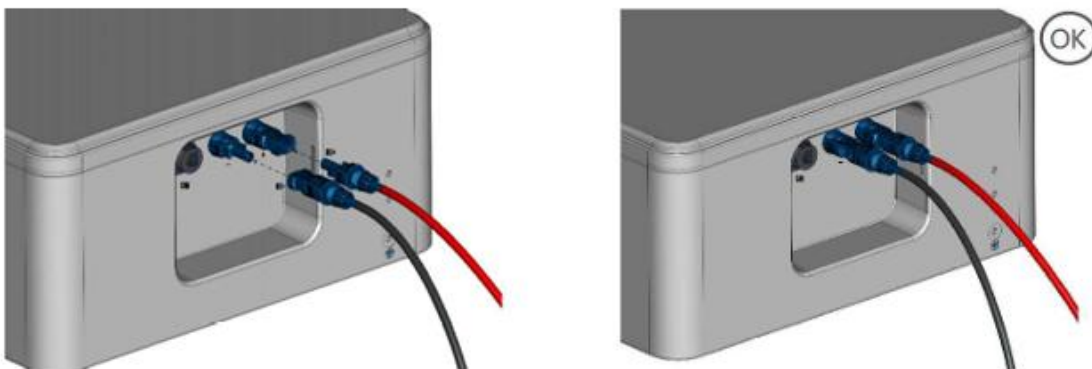

Step 3:

Insert the communication cable connector on the communication port of the Master-Unit. The other side of the communication cable is connected to the port „BMS“ of the inverter.

Note: A standard LAN cable is used for the communication connection between the battery and the inverter

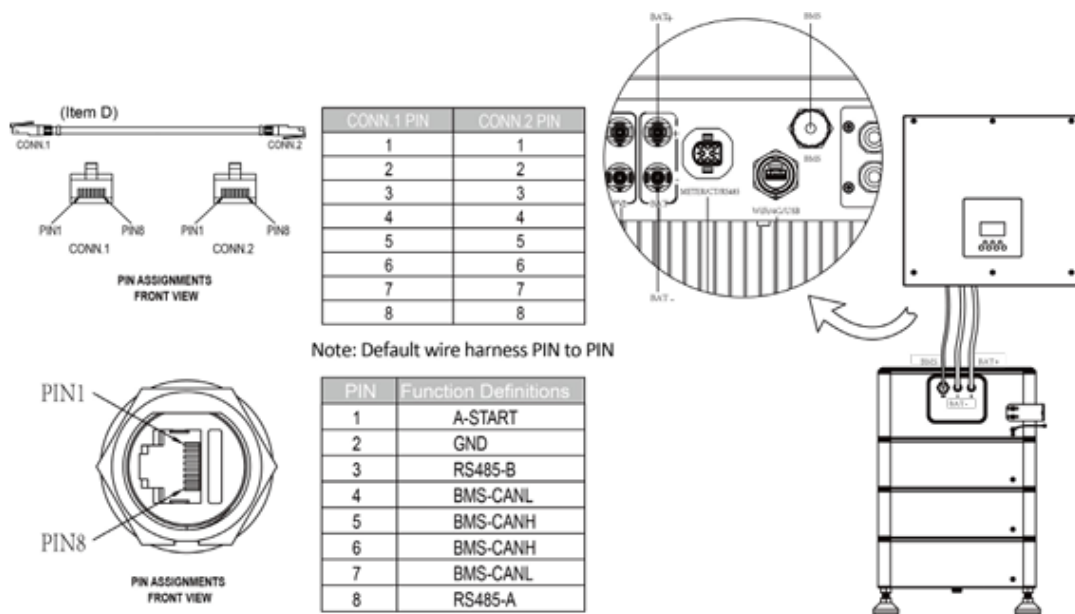

Step 4:

Connect the earthing cable to ensure that all batteries are earthed. The earthing cable must be connected to the earthing screw as shown below.

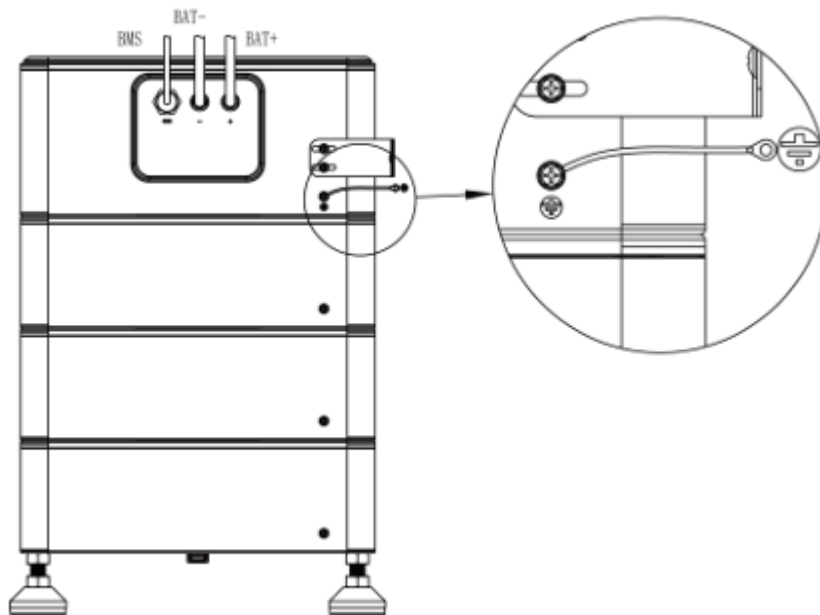

7.5. System Startup

- When the grid-connected system is put into operation, the inverter must be switched on first to prevent the current pulse of the inverter increasing to the battery pack.
- All installations and operation must comply with local electrical norms.
- Check all power cables and communication cables carefully.

Turn on the POWER switch:

- Before you start, please set the DIP switch to the correct position. DIP stands for the number of slave units + master unit minus two in the system.
- Normal mode: If the PV and the grid connection is available, first switch on the DC switch and then press the "POWER" button on the Battery.
- Black start: If there is no PV and no grid connection, first switch on the DC switch, then press the "POWER" button. Afterwards hold down the "B-Start" button and release it after 10s.
- The alarm indicator and the alarm LED on the NGEN STAR Master/Slave Unit light up simultaneously for 1 second to confirm that the system has been successfully switched on. This alarm indicator is displayed in "Normal mode" and "Black start".

8. Commissioning

The operating status light on the left-hand side of the battery pack indicates the operating status.

For NGEN STAR Master-Unit

SOC	Status	Green LED	Red LED	LED4-1			
=100%	Standby	■	/	●	●	●	●
100% > SOC >= 75%		■	/	●	●	●	●
75% > SOC >= 50%		■	/	/	●	●	●
50% > SOC >= 25%		■	/	/	/	●	●
25% > SOC >= 0%		■	/	/	/	/	●
=100%	Discharge	●	/	●	●	●	●
100% > SOC >= 75%		●	/	●	●	●	●
75% > SOC >= 50%		●	/	/	●	●	●
50% > SOC >= 25%		●	/	/	/	●	●
25% > SOC >= 0%		●	/	/	/	/	●
=100%	Charge	●		■	■	■	■
100% > SOC >= 75%		●		■	■	■	■
75% > SOC >= 50%		●		/	■	■	■
50% > SOC >= 25%		●		/	/	■	■
25% > SOC >= 0%		●	/	/	/	/	■

Error messages – for NGEN STAR Master-Unit

Fault	Green LED	Red LED	LED4-1			
Under voltage error	/	■	/	/	/	●
Over voltage error	/	■	/	/	●	/
Over temperature failure	/	■	/	/	●	●
Under temperature failure	/	■	/	●	/	/
Discharge over current	/	■	/	●	/	●
Charge over current	/	■	/	●	●	/
Discharge over power	/	■	/	●	●	●
Charge over Power	/	■	●	/	/	/
Pre-Charge failed	/	■	●	/	/	●
Short circuit protection	/	■	●	/	●	/
AFE-Communication failed	/	■	●	/	●	●
Module Addressing failed	/	■	●	●	/	/
IVU-Communication failed	/	■	●	●	/	●
BMU-Communication failed	/	■	●	●	●	/
PCS-Communication failed	/	■	●	●	●	●
HVB FUSE-Fault	/	●	/	/	/	●
Modul FUSE-Fault	/	●	/	/	●	/

Power failed	/	●	/	/	●	●
Intern total voltage sampling failed	/	●	/	●	/	/
Temperature sampling failed	/	●	/	●	/	●
Relay adhesion	/	●	/	●	●	/
Relay not closed	/	●	/	●	●	●
Relay drive failed	/	●	●	/	/	/
Single cell "0V" fault	/	●	●	/	/	●
Temperature high permanently failed	/	●	●	/	●	/
The Single voltage high permanently failed	/	●	●	/	●	●
SOH low protection	/	●	●	●	/	/
AFE failed (UV/OV/UT/OT)	/	●	●	●	/	●
Shutdown failed	/	●	●	●	●	/
Other fault	/	●	●	●	●	●

For NGEN STAR Slave-Unit

Green LED	Red LED	Batteries Status
On for 0,5s, Off for 0,5s	On for 0,5s, Off for 0,5s	Running in boot
On for 0,1s, Off for 0,1s	On for 0,1s, Off for 0,1s	Upgrading
On for 1s, Off for 1s	Off	Normal Operation
Off	On for 1s, Off for 1s	Alarm

Remark: ■ : LED flash indicator (ON: 0,5s, OFF: 0,5s) ● : LED flash indicator (Permanent LED)

9. Exclusion

The warranty does not cover defects caused by normal wear and tear, improper maintenance, handling, storage, faulty repair, modifications to the battery or battery pack by a third party other than NGEN or a company authorized by NGEN, failure to follow the product specifications provided herein, or improper use or installation, including but not limited to the following.

- Damage during transport or storage.
- Improper installation of the batteries in the pack or maintenance.
- Use of the battery pack in an unsuitable environment.
- Improper, inadequate, or incorrect charging, discharging or production cycle not described in this manual.
- Improper or inappropriate use.
- Insufficient ventilation.
- Non-compliance with the applicable safety warnings and instructions.
- Interventions or attempted repairs by unauthorized personnel.
- In the event of force majeure (e.g. lightning, storm, flood, fire, earthquake, etc.).

- There are no warranties - implied or express - other than those set forth herein. NGEN shall not be liable for consequential or indirect damages arising out of or in connection with the product specification, battery, or battery pack.

10. Troubleshooting and Maintenance

10.1. Maintenance

- Regularly check whether the operating environment of the battery meets the requirements, and the installation position should be far away from a heat source.
- The battery module should be stored in an environment with a temperature range between -20°C-+55°C and regularly charged to a SOC (State of charge) of 50% according to the table below after a long storage period.

Storage environment temperature	Relative humidity of the storage environment	Storage time	SOC
Below -20°C	/	Not allowed	/
-20~35°C	5%~70%	≤ 6 Months	20%≤SOC≤60%
35~55°C	5%~70%	≤ 3 Months	20%≤SOC≤60%
Above 55°C	/	Not allowed	/
NOTICE			
Damage to the system due to undervoltage: <ul style="list-style-type: none"> – Charge the over-discharged system within seven days if the temperature is above 25°C. – Charge the over-discharged system within fifteen days if the temperature is below 25°C. 			

- Regularly check that the battery and its terminals, connecting cables and indicator lights are in good condition.

10.2. Troubleshooting

If the red/green LED on the control panel flashes or lights up normally, this does not mean that the NGEN STAR Slave-Unit has a fault. It may just be an alarm or a protective function. Please check the "LED status displays" for a detailed fault definition before you start troubleshooting. When the alarm state is cancelled, the NGEN STAR Slave-Unit automatically returns to normal operation.

- The problem definition is based on the following points

1. Whether the green light on the battery is illuminated.
2. Whether the power button in the NGEN STAR Master-Unit is switched on.
3. Whether the battery system is communicating with the inverter.
4. Whether the battery is supplying an output voltage. The Voltage can be read out on the inverter.

- Preliminary determination steps

1. The LED display of the NGEN STAR Master-Unit and NGEN STAR Slave-Unit is normal, but it cannot charge and discharge. Observe the display of the inverter to see if the battery status is displayed. Check whether the CAN communication between the NGEN STAR Master-Unit and the inverter is properly connected. If the connection is not made properly, please replace the CAN communication cable between the NGEN STAR Master-Unit and the inverter in the next step. If the battery status is still not shown on the inverter display, please contact your local manufacturer.
2. If you can see the alarm information on the LED and inverter display at the same time after turning on the battery system, please contact the local dealer.
3. If the battery system does not work, the LED does not light up or flashes when switching on DC and power, please contact the local manufacturer.

The copyright of this manual belongs to NGEN d.o.o. No legal or natural person may copy this manual, either in whole or in part (including software), nor is the distribution or reproduction of the manual in any form or manner permitted. All rights reserved by NGEN d.o.o., Moste 101, 4274 Žirovnica, Slovenia. www.NGEN.si.