

# **NGEN STAR EP11 BATTERY INSTALLATION MANUAL**

## Table of Contents

1.	Introduction .....	3
2.	Symbols.....	3
3.	Safety .....	4
3.1.	Handling .....	4
3.2.	Installation .....	4
4.	Response to Emergency Situations .....	5
5.	Product Information .....	6
5.1.	NGEN STAR EP11 Battery Specifications.....	6
6.	Product Features .....	7
6.1.	Battery System Features .....	7
7.	Installation .....	8
7.1.	Scope of Delivery .....	8
7.2	Space requirement .....	8
7.3	Required Tools.....	9
7.4.	Installation Steps .....	10
8.	Electrical Connection .....	11
8.1.	Wiring Steps (Single system) .....	11
8.2.	Wiring steps (parallel system max. 4 Batterys).....	13
8.3.	System Startup.....	15
8.4.	System black start .....	15
9.	Commissioning.....	16
10.	Exclusion.....	18
11.	Troubleshooting and Maintenance.....	18
11.1.	Maintenance .....	18
11.2.	Troubleshooting.....	19

## ENGLISH

Read the instruction carefully before installation. Failure to do so may result in personal injury and damage to property or invalidate the warranty and product guarantee. Installation requires specialist knowledge and may therefore only be carried out by appropriately qualified and authorized specialists!







The general handling of the product, its use or the exact installation methods are beyond the control of NGEN. Therefore, NGEN cannot accept any responsibility for damages, losses or cost resulting from improper installation, improper handling of the incorrect use!





### 1. Introduction

The document describes the installation, commissioning, maintenance and troubleshooting of the NGEN high voltage battery: NGEN-STAR EP11 Battery

The battery chemistry of these products is Lithium Iron Phosphate (LiFePO4). This manual is designed for qualified personnel only. These tasks described in this document should be performed by authorized and qualified technicians only. After the Installation the Installer must explain the user manual to the end user.

### 2. Symbols

	Symbol Explanation CE mark. The Battery complies with the requirements of the applicable CE guidelines.
	Attention, risk of electronic shock
	Do not place or install near flammable or explosive materials.
	Install the product out of reach of children.
	Read the instruction manual before starting installation and operation.
	Do not dispose of the products with household wastes.
	The use of water to extinguish fires is prohibited.

	Prevent reverse polarity of the connections.
	Disconnect the equipment before carrying out maintenance or repair.
	Observe precautions for handling electrostatic discharge sensitive devices.
	Protective conductor connection

### 3. Safety

Any work on the Batteries should be handled by authorized technicians and hence it is understood that the technicians should familiarize themselves with the contents of this manual before any maintenance or installation is carried out on the system.

#### 3.1. Handling

- Do not expose battery to open flame.
- Do not place the product under direct sunlight.
- Do not place the product near flammable materials. It may lead to fire or explosion in case of accident.
- Store in a cool and dry place with ample ventilation.
- Do not store the product near water sources.
- Store the product on a flat surface.
- Store the product out of reach of children and animals.
- Do not damage the unit by dropping, deforming, impacting, cutting or penetrating with a sharp object. It may cause leakage of electrolyte or fire.
- Do not touch any liquid spilled out of the product. There is a risk of electric shock or damage to skin.
- Always handle the battery wearing the insulated gloves.
- Do not step on the product or place any foreign objects on it. This can result in damage.
- Do not charge or discharge damaged battery.

#### 3.2. Installation

- Do not connect the NGEN-STAR battery to the conductors of the inverter or the photovoltaic system. This will damage the battery and may lead to an explosion.
- Check the product for damage and missing parts after unpacking.
- Make sure that the inverter and the battery are completely switched off before starting the installation.
- Do not reverse the positive and negative poles of the battery.

- Ensure that there is no short circuit between the terminals or with an external device.
- Do not exceed the permissible battery voltage of the inverter.
- Do not connect the battery to an incompatible inverter.
- Do not connect different battery types together.
- Ensure that all batteries are properly earthed.
- Do not open the battery to repair or dismantle it. Such repairs may only be carried out by the manufacturer.
- Only use dry powder fire extinguishers in case of fire. Liquid fire extinguishers must not be used.
- Only install the batteries in an approved building. Installing the battery outdoors is not recommended.
- Do not install the battery near water sources or in places where the battery may get wet.
- Do not install the battery near children or pets.
- Do not use the battery in environments with a high static charge where the protective device could be damaged.

## 4. Response to Emergency Situations

The batteries consist of several batteries connected in series. They are designed to prevent hazards or failures. However, their absolute safety cannot be guaranteed.

- In case of contact with the internal materials of the battery, the user should follow the recommendations below.
- In case of inhalation, leave the contaminated area immediately and seek medical attention.
- In case of contact with eyes, rinse eyes with running water for 15 minutes and seek medical attention immediately.
- In case of contact with skin, wash affected area thoroughly with soap and seek medical advice immediately.
- If swallowed, induce vomiting and seek medical attention.

### Fire Situation

In situations where the battery is on fire, if it is safe to do so, switch off the battery by turning off the circuit breaker to disconnect the power supply to the system. Use an FM-200 or Co2 fire extinguisher for the battery and an ABC fire extinguisher for the other parts of the system.

In any fire situation, please evacuate people from the building immediately before attempting to extinguish the fire.

### Water Situation

The battery modules are not waterproof. Therefore, make sure that they do not get wet. If the battery is fully or partially submerged in water, do not attempt to open it. Contact authorized personnel or NGEN for further instructions.

## 5. Product Information

### 5.1. NGEN STAR EP11 Battery Specifications

Specifications for NGEN STAR EP11 Battery	
Model	NGEN STAR EP11
Nominal capacity [Ah]	27
Nominal voltage [V]	384
Nominal energy [kWh]	10.36
Battery voltage range [Vdc]	348 - 438
Max. Charging/Discharging current [A]	27
Recommended Charging Current (CC-CV) [A]	13.5
Constant current and constant voltage charging cut-off current (A)	2
Peak charging current (5s) [A]	32.4
Peak discharging current (30s) [A]	65
Cycle life	>4000 @25°C @90% DOD
Storage temperature [°C]	0 - 35
Operating temperature range [°C]	Charge: 0 - 55 Discharge: -10 - 55
Discharge Capacity [Ah]	19@1C@-20 ±2°C 27@1C@25 ±2°C
Energy density [Wh/kg]	≥102
Ingress protection	IP65
Communication	CAN
Altitude [m]	≤2000
Weight [kg]	99 ±2
Dimensions (L x W x H) [mm]	710 x 147 x 625
Certificates	IEC62619; EN IEC 61000-6-1/3 ; UN38.3

## 6. Product Features

### 6.1. Battery System Features

The batteries are equipped with several protection systems to ensure the safe operation of the system. The protection systems include:

- Inverter interface protection: Overvoltage, overcurrent, external short circuit, reverse polarity, ground fault, overtemperature, overcurrent
- Battery protection: internal short circuit, overvoltage, overcurrent, overtemperature, undervoltage

The battery system has the following interfaces so that it can be connected and operated efficiently.

#### NGEN STAR EP11 Battery Features:

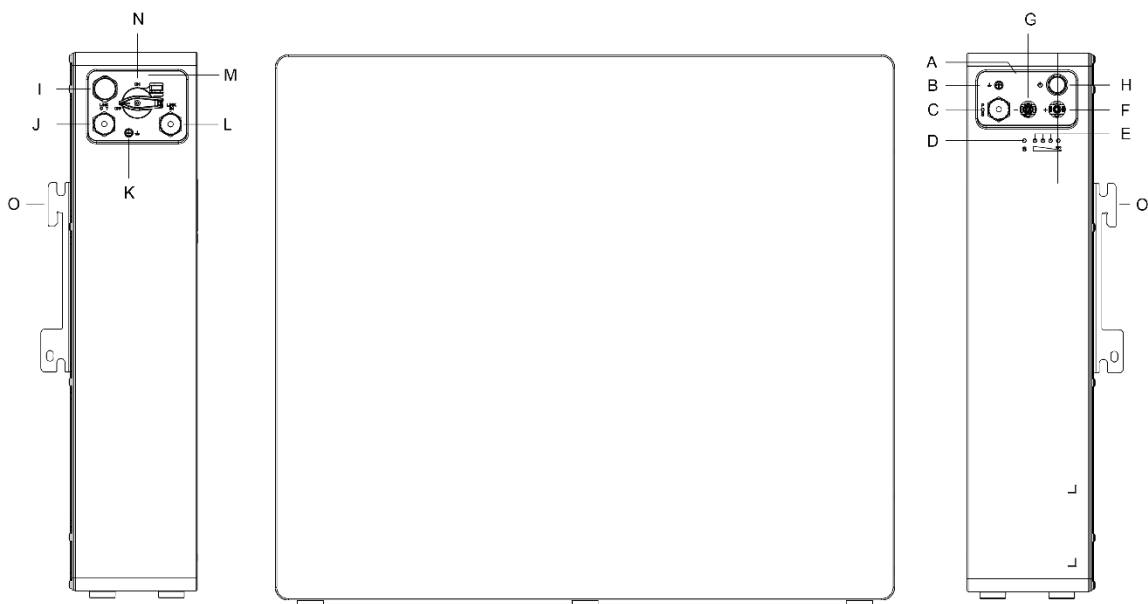

Position	Description	Position	Description	Position	Description
<b>A</b>	Handle	<b>F</b>	DC+	<b>K</b>	Ground Terminal
<b>B</b>	Ground Terminal	<b>G</b>	DC-	<b>L</b>	LINK IN
<b>C</b>	PCS COM	<b>H</b>	Power Switch	<b>M</b>	Handle
<b>D</b>	BMS-Status LED	<b>I</b>	Valves	<b>N</b>	DC-Switch
<b>E</b>	BMS SOC LED	<b>J</b>	LINK OUT	<b>O</b>	Battery bracket

#### Ground Terminal

This terminal is used to connect the battery to earth.

#### Handle

The handle is used to carry or move the battery.

#### DC-Switch

Main switch, battery charge and discharge circuit switch

#### DC+

Connect this output to Bat + of the inverter.

#### DC-

Connect this output to Bat – of the inverter.

#### Power Switch

Press this switch for about 3 seconds and the systems starts to work.

#### BMS-Status-LED and SOC-LED

LED display specific alarm information and battery system power.

## 7. Installation

### 7.1. Scope of Delivery

Please check carefully that all listed components are included in the scope of delivery.

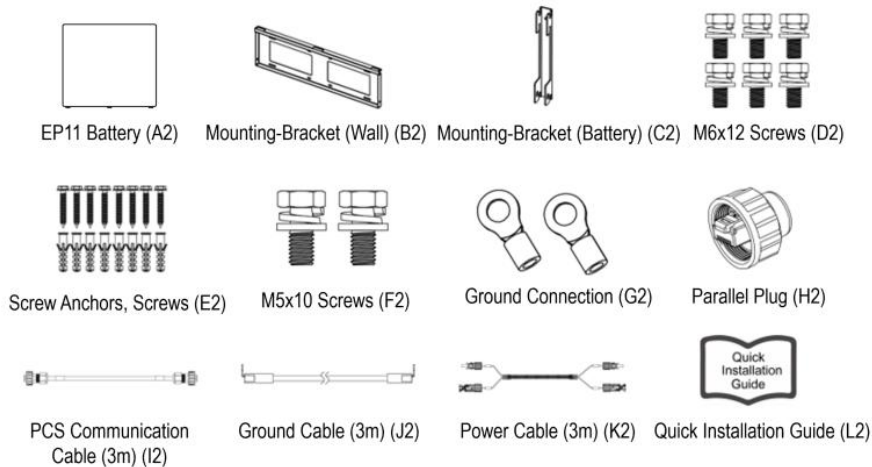

### 7.2 Space requirement

#### Standing mounting:

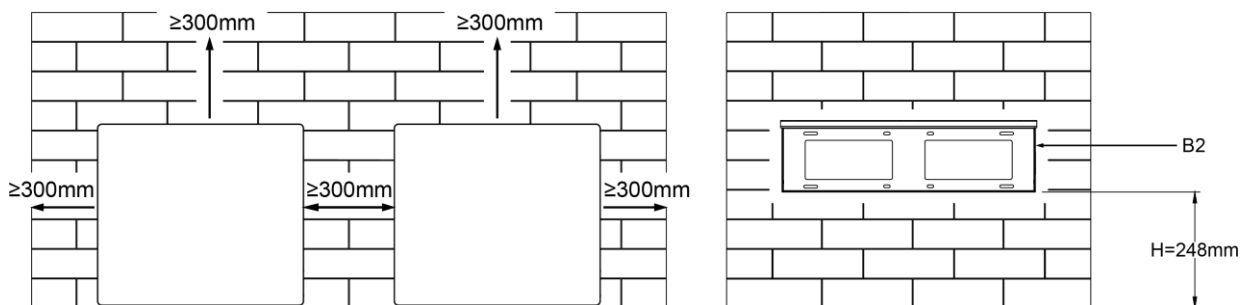

#### Wall mounting:

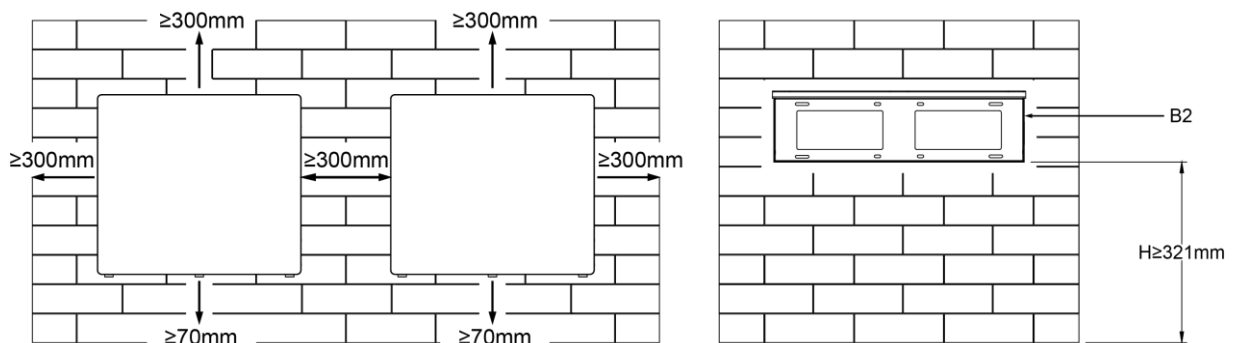

A clearance of at least 300 mm must be maintained around the battery pack to ensure cooling.

**Attention:** Ensure that the battery is installed in a room with adequate ventilation. The battery is cooled by natural convection. If the battery pack is completely or partially covered or shielded, this may result in the battery pack no longer functioning.

### 7.3 Required Tools

The following tools are required for the installation of the NGEN STAR EP11 Battery:



Screwdriver



Crimping tool



Safety Shoes



Multimeter



Safety Gloves



Safety Goggles



Hexagon socket wrench



Cable Ties



Electric Drill



Spirit Level



Rubber Hammer



Marker

## 7.4. Installation Steps

### Step 1: Attach the mounting bracket to the wall

- Position the wall bracket on the wall, use a spirit level (K1) to check the alignment of the bracket and mark the positions of the 4 holes.
- Remove the wall bracket and drill the holes with an electric drill (diameter 8mm, depth 45-50mm) and fix the bracket to the wall using the screw anchors and screws (E2) supplied.

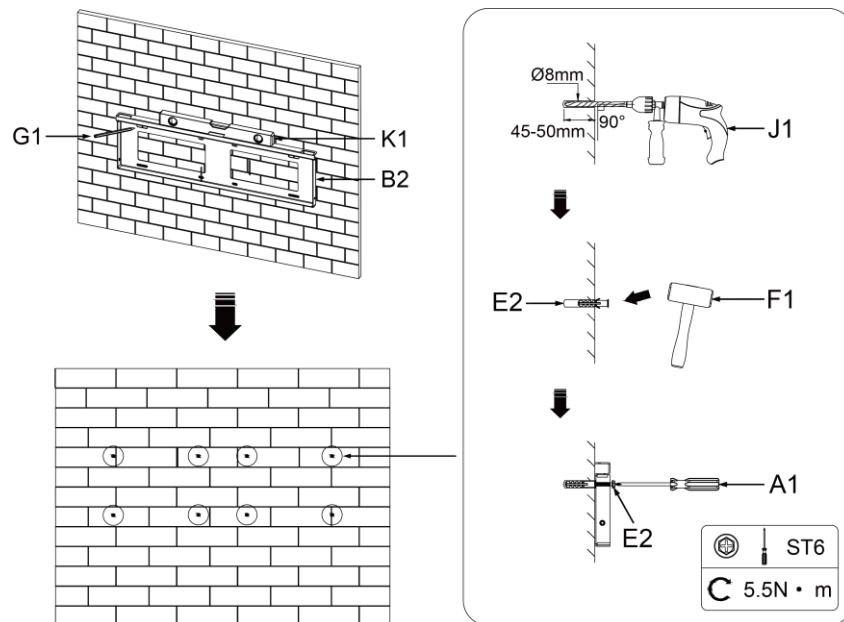

**Danger!**  
Before drilling, make sure that the water and electricity lines in the wall are not damaged at the installation site of the wall bracket in order to avoid hazards.

### Step 2: Hang the Battery on the wall bracket

- Hang the battery into the wall bracket from top to bottom.
- Make sure that the holes of the battery holder and the mounting bracket on the wall are aligned on the left and right sides.

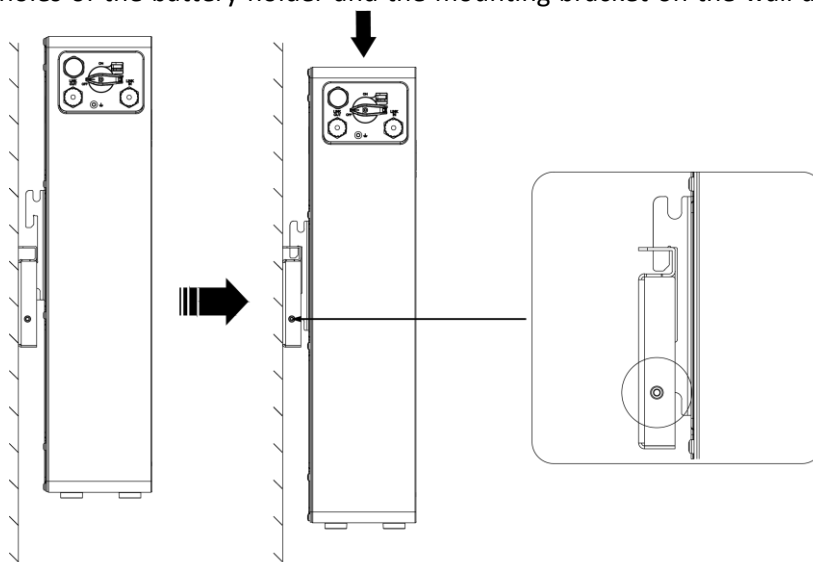

### Step 3: Secure the battery to the wall bracket

- Secure the battery on the left and right side of the wall bracket using the screws (F2) supplied.

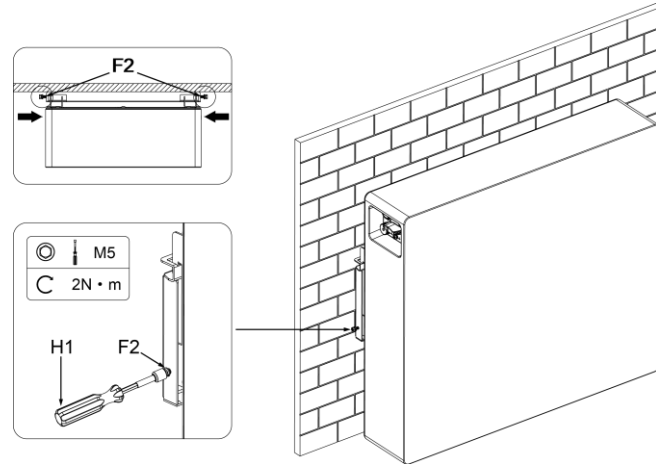

## 8. Electrical Connection

### 8.1. Wiring Steps (Single system)

#### Step 1: DC connection

- Connect the power cable (K2) to the DC connectors of the NGEN STAR EP11 Battery. The DC+ must be connected to the Battery (DC+) and the DC- to the Battery (DC-) connector.
- Push the connectors until they are locked with a „Click“ sound.

**Note:** For the wiring of the inverter, please refer to the user manual of the inverter.

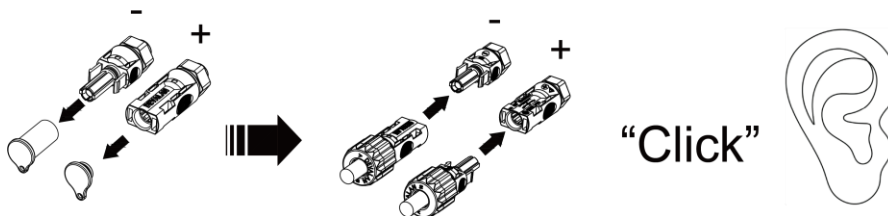

#### Step 2: PCS communication Connection

- Insert the PCS communication (I2) cable connector on the PCS port of the NGEN STAR EP11 Battery. The other side of the communication cable is connected to the port „BMS“ of the inverter.

**Note:** A standard LAN cable (CAT5) is used for the communication connection between the battery and the inverter.

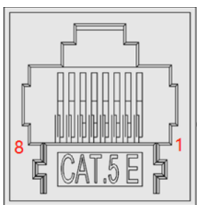

PIN	Function Description	Function Declaration
1	PCS_Wake+	Wakeup+
2	PCS_Wake-	Wakeup-
3	N/A	N/A
4	PCS_CANL	CANL
5	PCS_CANH	CANH
6	PCS_CANH	CANH
7	PCS_CANL	CANL
8	N/A	N/A

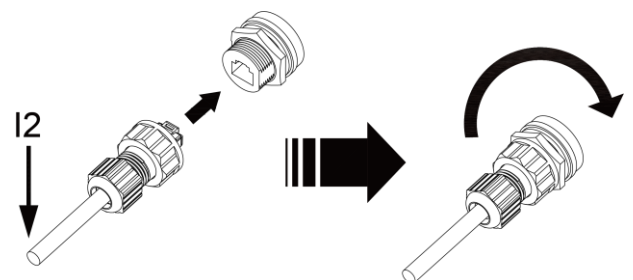

#### Step 4: Grounding connection

- Connect the grounding cable (J2) to ensure that the battery is earthed. The grounding cable must be connected to the earthing screw (F2) as shown below.

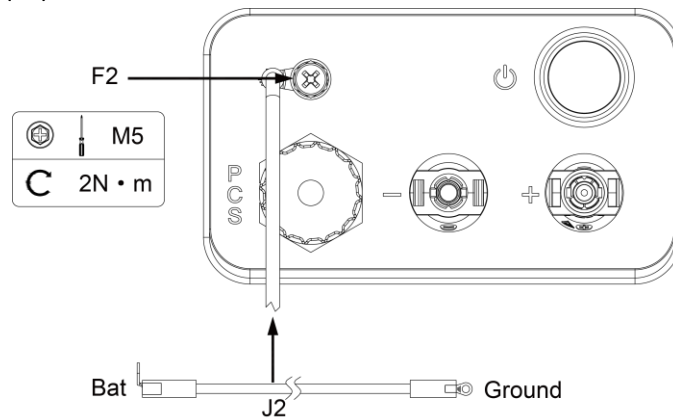

#### Step 5: Closing the parallel communication connections

- Close the parallel communication connections with the parallel plugs (H2) supplied.  
**Note:** Failure to install the parallel plugs will impair the proper function of the battery.

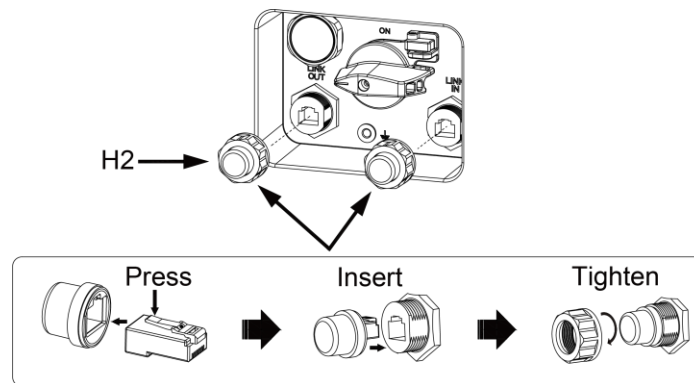

#### Step 6: Connecting the battery to the inverter

For the wiring of the inverter, please refer to the user manual of the inverter.

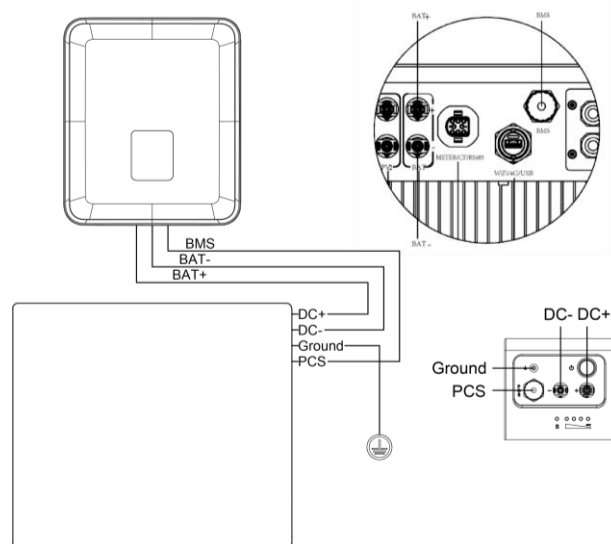

## 8.2. Wiring steps (parallel system max. 4 Batterys)

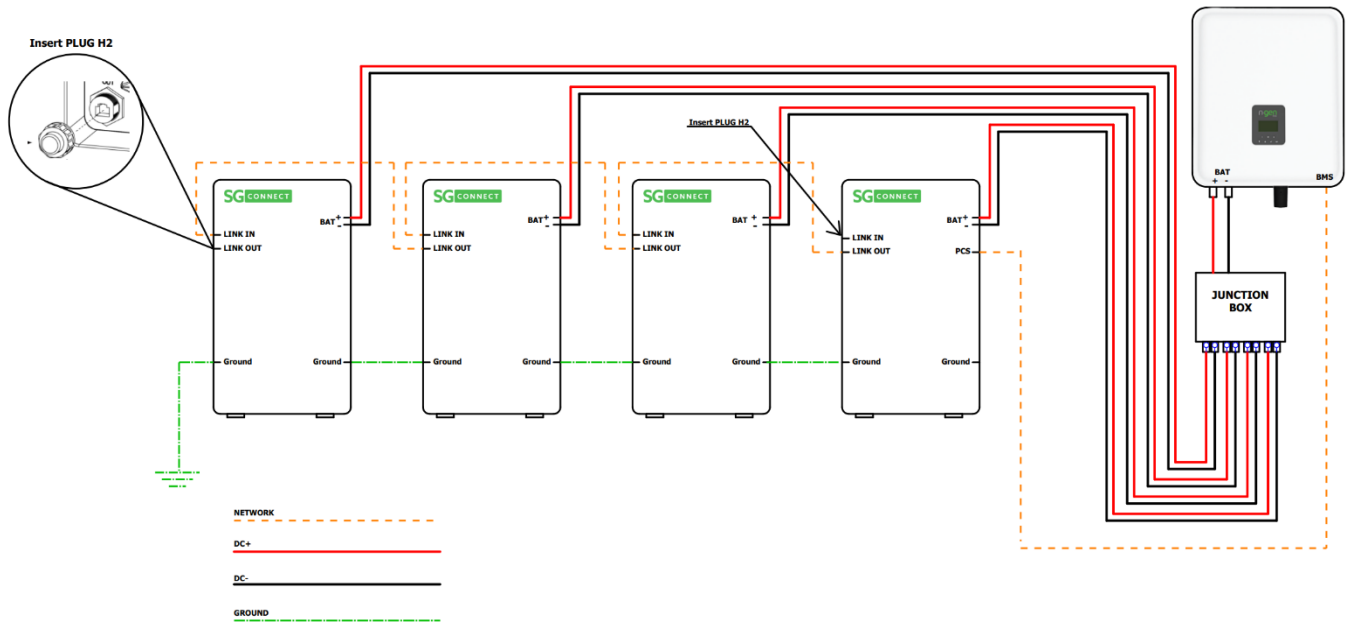

### Step 1: Connecting the parallel cables between the batteries

- Insert the parallel plug (H2) into the „LINK IN“ port. This battery is then also defined as the master battery.

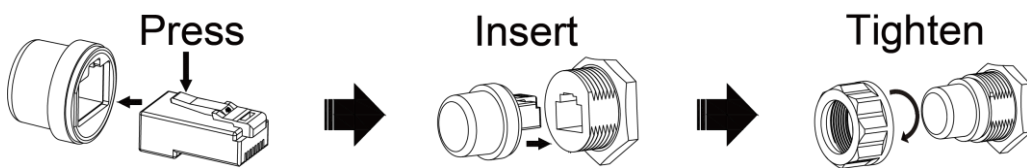

- Use the communication cable (I2) to connect the „LINK OUT“ port of the master battery to the „LINK IN“ of the next battery. Start with the „LINK OUT“ port of the master battery and continue until you reach the „LINK IN“ connection of the last battery. Insert the second parallel plug (H2) into the „LINK OUT“ port of the last battery.

**Note:** A standard LAN cable (CAT5) is used for the communication connection between the battery and the inverter.

#### LINK IN

#### LINK OUT

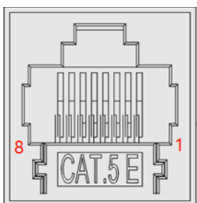

PIN	Function Description	Function Declaration
1	Main_SL	Main_SL
2	RACK_CANL	CANL
3	N/A	N/A
4	N/A	N/A
5	RACK_CANH	CANH
6	ISO_GND	GND
7	Sync_WKEOUT	WakeupIn
8	Encode_IN	Encode_IN

PIN	Function Description	Function Declaration
1	Last_SL	Last_SL
2	RACK_CANL	CANL
3	N/A	N/A
4	N/A	N/A
5	RACK_CANH	CANH
6	ISO_GND	GND
7	Sync_WKEOUT	WakeupOut
8	Encode_OUT	Encode_OUT

Step 2: Connecting the inverter cables

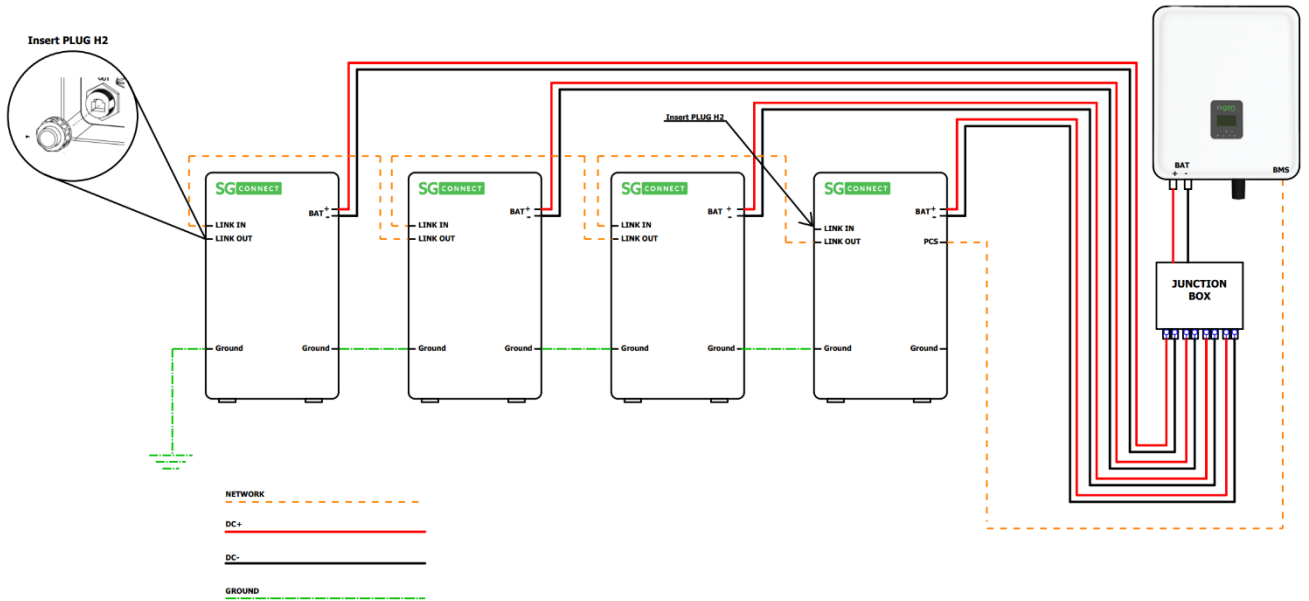

- Connect the ground cable (J2) from the ground terminal of the Master battery (left side of the battery) to the ground terminal of the next battery (right side of the battery) and continue the same connection until the ground terminal of the last battery (left side of the battery).

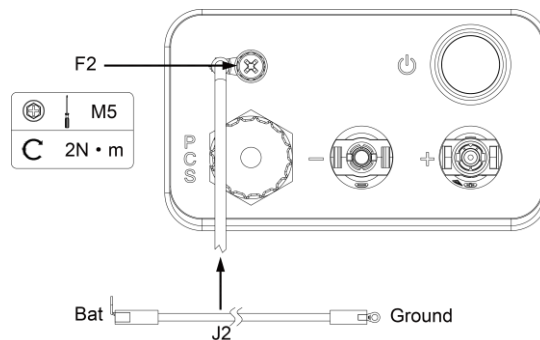

- Connect the PCS communication cable (I2) of the Master battery to the BMS communication port of the inverter.

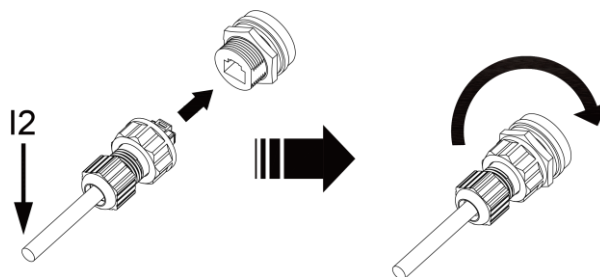

- Connect the power cable (K2) of each battery to the junction box (to be purchased separately) and the output cable of the junction box to the battery connection of the inverter.

**Note:** For the wiring of the inverter, please refer to the user manual of the inverter.

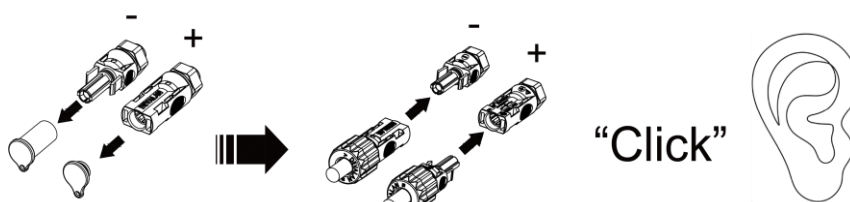

### **8.3. System Startup**

To start the battery system, follow the steps below:

- When the grid-connected system is put into operation, turn on the battery first to ensure that the battery voltage output is normal, then turn on the inverter.
- All installations and operation must comply with local electrical norms.
- Check all power cables and communication cables carefully.
- Turn the DC switch of each battery to the "ON" position and then press and hold the power button of the Master battery for about 3 seconds.
- Each battery LED lights up and flashes at the start of operation to indicate that the battery is switched on.

### **8.4. System black start**

In special cases, e.g. if there is no access to the power grid, the battery can activate the inverter via the "Black Start" function. During the black start function, the associated photovoltaic system is also in operation. To activate the black start function, follow the steps below:

- Press the power button on the Master battery for 1-3 seconds (no longer than 5 seconds) and then release the button to activate the black start function.
- If the status LED of at least one battery lights up green and remains constant and the status LEDs of the remaining batteries do not light up red, this indicates that the batteries have switched to normal operating status.

## 9. Commissioning

There are five LED indicators to show its operating status. Different symbols indicate different flashing modes, and the explanation is as follows:

Symbol	Status
■	LED flash display (ON: 0.5s ; OFF: 0.5s)
/	LED off display
●	LED on display

The operating status light on the right-hand side of the battery indicates the operating status:

SOC	Status	S LED	SOC LED4-1			
100% ≥ SOC > 75%	Standby	■	●	●	●	●
75% ≥ SOC > 50%		/	●	●	●	
50% ≥ SOC > 25%		/	/	●	●	
25% ≥ SOC ≥ 0%		/	/	/	●	
=100%	Discharge	●	●	●	●	●
100% > SOC ≥ 75%		●	●	■	■	■
75% > SOC ≥ 50%		●	●	/	■	■
50% > SOC ≥ 25%		●	●	/	/	■
25% > SOC ≥ 0%	●	●	/	/	/	
100% ≥ SOC > 75%	Charge	●	●	●	●	●
75% ≥ SOC > 50%		●	●	/	●	●
50% ≥ SOC > 25%		●	●	/	/	/
25% ≥ SOC ≥ 0%		●	●	●	●	●

### Error messages

Fault	S LED	SOC LED4-1			
Under voltage fault	■	/	/	/	●
Over voltage fault	■	/	/	●	/
Over temperature fault	■	/	/	●	●
Under temperature fault	■	/	●	/	/
Discharge over current	■	/	●	/	●
Charge over current	■	/	●	●	/
Reserve	■	/	●	●	●
Parallel addressing failure	■	●	/	/	/
Pre-Charge failed	■	●	/	/	●
Short circuit protection	■	●	/	●	/
AFE-Communication failed	■	●	/	●	●
Module Addressing failed	■	●	●	/	/

Internal-Communication failed	■	●	●	/	●
Power parallel failure	■	●	●	●	/
PCS-Communication failed	■	●	●	●	●
HVB FUSE fault	●	/	/	/	●
Current sampling fault	●	/	/	●	/
Module not match	●	/	/	●	●
Intern total voltage sampling failed	●	/	●	/	/
Temperature sampling failed	●	/	●	/	●
Relay adhesion	●	/	●	●	/
Relay not closed	●	/	●	●	●
Relay drive failed	●	●	/	/	/
Cell "OV" fault	●	●	/	/	●
Temperature high permanent failed	●	●	/	●	/
The Single voltage high permanently failed	●	●	/	●	●
SOH low protection	●	●	●	/	/
AFE failed (UV/OV/UT/OT)	●	●	●	/	●
Charger overvoltage	●	●	●	●	/
Other fault	●	●	●	●	●

## 10. Exclusion

The warranty does not cover defects caused by normal wear and tear, improper maintenance, handling, storage, faulty repair, modifications to the battery or battery pack by a third party other than NGEN or a company authorized by NGEN, failure to follow the product specifications provided herein, or improper use or installation, including but not limited to the following.

- Damage during transport or storage.
- Improper installation of the batteries in the pack or maintenance.
- Use of the battery pack in an unsuitable environment.
- Improper, inadequate, or incorrect charging, discharging or production cycle not described in this manual.
- Improper or inappropriate use.
- Insufficient ventilation.
- Non-compliance with the applicable safety warnings and instructions.
- Interventions or attempted repairs by unauthorized personnel.
- In the event of force majeure (e.g. lightning, storm, flood, fire, earthquake, etc.).
- There are no warranties - implied or express - other than those set forth herein. NGEN shall not be liable for consequential or indirect damages arising out of or in connection with the product specification, battery, or battery pack.

## 11. Troubleshooting and Maintenance

### 11.1. Maintenance

- It is recommended that the battery storage time is not more than 6 months.
- Regularly check whether the operating environment of the battery meets the requirements, and the installation position should be far away from a heat source.
- The battery module should be stored in an environment with a temperature range between 0°C and +35°C and charged regularly according to the table below with no more than 0.5 C (A C rate is a measure at which a battery is discharged in relation to its maximum capacity.) to an SOC (state of charge) of 50% after a long storage period.

Storage environment temperature	Relative humidity of the storage environment	Storage time	SOC
Below 0°C	/	Not allowed	/
0 - 35°C	45% - 85%	≤ 6 Months	20%≤SOC≤50%
Above 35°C	/	Not allowed	/
<b>NOTICE</b>			
Damage to the system due to undervoltage: <ul style="list-style-type: none"> <li>– Charge the over-discharged system within seven days if the temperature is above 25°C.</li> <li>– Charge the over-discharged system within fifteen days if the temperature is below 25°C.</li> </ul>			

- Regularly check that the battery and its terminals, connecting cables and indicator lights are in good condition.
- Make sure that the connections are not loose, broken or corroded. Also check the installation environment for dust, water, insects, etc.

## **11.2. Troubleshooting**

If the S LED on the control panel flashes or lights up normally, this does not mean that the battery has a fault. It may just be an alarm or a protective function. Please check the "LED status displays" for a detailed fault definition before you start troubleshooting. When the alarm state is cancelled, the battery automatically returns to normal operation.

### **The problem definition is based on the following points:**

1. Whether the green light on the power button is on.
2. Whether the power button is switched on.
3. Whether the battery system is communicating with the inverter.
4. Whether the battery is supplying an output voltage. The Voltage can be read out on the inverter.

### **Preliminary determination steps:**

1. The LED of the battery is normal, but it cannot charge and discharge. Observe the display of the inverter to see if the battery status is displayed. Check whether the communication between the BMS and the inverter is properly connected. If the connection is not made properly, please replace the communication cable between the BMS and the inverter in the next step. If the battery status is still not shown on the inverter display, please contact your local manufacturer.
2. If you can see the alarm information on the LED and inverter display at the same time after turning on the battery system, please contact the local dealer.
3. If the battery system does not function, meaning the LED does not light up or flash when the DC switch is turned on or the power button is pressed, please contact the local manufacturer.

The copyright of this manual belongs to NGEN d.o.o. No legal or natural person may copy this manual, either in whole or in part (including software), nor is the distribution or reproduction of the manual in any form or manner permitted. All rights reserved by NGEN d.o.o., Moste 101, 4274 Žirovnica, Slovenia.  
[www.NGEN.si](http://www.NGEN.si)