

ASSEMBLY INSTRUCTION
NGEN STAR EV-CHARGER 7kW

Table of Contents

1.	Hints for this Manual	3
1.1.	Range of Validity	3
1.2.	Target Group	3
1.3.	Used Symbols	3
2.	Safety	4
2.1.	Proper Use of the Product	4
3.	Introduction.....	5
3.1.	Basic Features	5
3.2.	Explanation of the components on the EV-Charger	5
4.	Technical Specifications.....	6
4.1.	NGEN STAR EV7 Specifications	6
5.	Installation.....	7
5.1.	Scope of delivery	7
5.2.	Mounting guidelines	7
5.3.	Required tools.....	8
5.4.	Assembly steps Wall Mounting.....	8
6.	Electrical Connection.....	10
6.1.	AC-Connection to the Grid.....	10
6.2.	Communication-Connection	12
7.	Energy Management	13
7.1.	Electrical Connection for the Energy Management.....	13
8.	Operation	14
8.1.	Charging Mode and Operation	14
8.1.1.	Controlled Mode.....	14
8.1.2.	Locked Mode	14
8.1.3.	Plug & Charge Mode.....	15
8.2.	Charger Status Indicators.....	16
9.	Maintenance.....	17
10.	Shutdown	18
10.1.	Dismantling the EV-Charger	18
10.2.	Packaging	18
10.3.	Storage and Transport	18

ENGLISH

Read this installation instruction carefully before installation. Failure to do so may result in personal injury and damage to property or invalidate the warranty and product guarantee. Installation requires specialist knowledge and may therefore only be carried out by appropriately qualified and authorized specialists!

The general handling of the product, its use or the exact installation methods are beyond the control of NGEN. Therefore, NGEN cannot accept any responsibility for damages, losses or cost resulting from improper installation, improper handling of the incorrect use!

1. Hints for this Manual

1.1. Range of Validity

The document describes the installation, commissioning, maintenance and troubleshooting for the following EV-Charger models: NGEN STAR-EV7









Note: Please keep these instructions in a place where they are always accessible.



1.2. Target Group

This manual is intended for qualified electricians. The tasks described in this manual can only be performed by qualified electricians.

1.3. Used Symbols

The following types of safety instructions and general information appear in this document as described below:

	Danger! "Danger" indicates a hazardous situation which, if not avoided, will result in death or serious injury.
	Warning! "Warning" indicates a hazardous situation which, if not avoided, could result in death or serious injury.
	Caution! "Caution" indicates a hazardous situation which, if not avoided, could result in minor or moderate injury.
	Note! "Note" provides important tips and instructions.
	Symbol Explanation CE-Mark. The EV-Charger complies with the requirements of the applicable CE directives.
	Caution, hot surface! The EV-Charger may heat up during operation. Avoid contact with the EV-Charger during operation.
	Danger of high voltage! High voltage inside the EV-Charger is life-threatening!
	Danger! Electric shock hazard!

	Read the manual.
	The product must not be disposed of as household waste.

2. Safety

2.1. Proper Use of the Product

The EV-Chargers have been developed and tested in accordance with international safety standards. However, certain safety procedures and measures must be followed during the installation and use of the EV-Charger. The installer must read and follow all instructions, cautions and warnings in this installation manual.

- All work, including transport, installation, commissioning, and maintenance of the device, must be performed by qualified and properly trained personnel.
- Electrical installation and maintenance of the EV-Charger must be carried out by a licensed electrician and must comply with the local wiring rules and regulations.
- Check the device before installation to ensure that it has not suffered any transportation or handling damage. Unauthorised removal of necessary protections, improper use of the device, improper installation and operation of the device can cause serious safety hazards and risk of electric shock or equipment damage.
- Do not install the equipment in unsuitable environments such as near flammable or explosive substances, in corrosive or desert environments, or in environments where the device would be exposed to extremely high or low temperatures, or where there is a high humidity.
- Do not use the equipment if the safety devices are not working or are deactivated.
- During the installation of the device, use personal protective equipment, including gloves and eye protection.
- In case of non-standard conditions for the installation of the device, inform the manufacturer.
- Do not use the device if operating anomalies are detected. Avoid temporary repairs of the device.
- All repairs are only allowed to be carried out with approved replacement parts, which must be installed according to their intended use and by licensed electrical partners or an authorized service technician.
- Liabilities arising from commercial components are delegated to their respective manufacturers.

3. Introduction

3.1. Basic Features

The NGEN STAR-EV 7.3 series are high-quality chargers designed to charge electric vehicles using electricity from the grid or excess energy from a solar power plant.

Advantages of the System:

- App operation or RFID authentication
- Type 2 charging plug
- Flexible Installation (Wall-mounted or column mounting)
- IP55 and IK08 protection
- Dynamic load balance (Dynamic adjustment of charging power)
- Scheduled time charging
- OCPP-Compliant (OCPP 1.6 Json or OCPP 2.0.1)
- Multiple connectivity options (Bluetooth, Wi-Fi, 4G, Ethernet)
- Solar linkage (surplus utilization of the photovoltaic system)

3.2. Explanation of the components on the EV-Charger

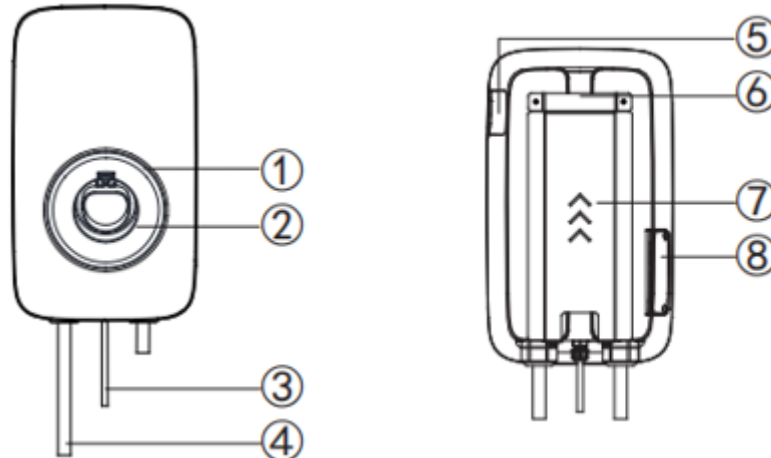

Pos.	Description	Pos.	Description
1	Status-LED	5	Stop Button
2	Plug Holder	6	Mounting-Bracket
3	RS485 Communication	7	Mounting-Backplate
4	AC-Input	8	Side Cover

Note: The Connection may only be made by an authorized person!

4. Technical Specifications

4.1. NGEN STAR EV7 Specifications

Model	NGEN STAR EV7
INPUT	
Wiring Scheme	1P+N+PE
Rated Voltage [Vac]	230 ±20%
Maximum Current [A]	32
Rated Frequency [Hz]	50 / 60
OUTPUT	
Rated Voltage [Vac]	230 ±20%
Maximum Current [A]	32
Rated Power [kW]	7.3
USER INTERFACE & CONTROL	
Connector Type	Type 2 cable
RFID-Reader	Mifare ISO / IEC 14443A
Start-up Mode	Plug&Charge / RFID card / App
COMMUNICATION	
Bluetooth	Yes
WiFi	Yes
OCPP 1.6 or 2.0	Yes
4G	Yes
LAN	Optional
ENVIRONMENT	
Installation	Wall-mounting / Column-mounting
Operating Temperature [°C]	from -25°C to +50°C
Operating Humidity	5% - 95% No condensation
Operating Altitude	≤2000m
DIMENSION AND WEIGHT	
Product Dimension [mm]	320 x 190 x 130
Product Weight [kg]	5.43
SAFETY	
IP protection rating	IP55
IK protection rating	IK08
Residual Current Detection	AC 30mA / DC 6mA
Electrical Protection	Over current protection, Residual current protection, Ground protection, Surge protection, Over/Under voltage protection, Over/Under frequency protection, Over/Under temperature protection
EMC	Class B
Certification	CE
Certification Standard	EN/IEC 61851-1: 2019, EN/IEC 61851-21-2: 2021

5. Installation

Before installing the device, make sure that the EV-Charger has not been damaged during transport. If there are visible damages, please contact the product seller immediately.

5.1. Scope of delivery

Open the charging pile packaging and take out the products, please check the accessories first. If damage or missing parts are found, do not boot up and inform the product seller. The packaging list is shown below:

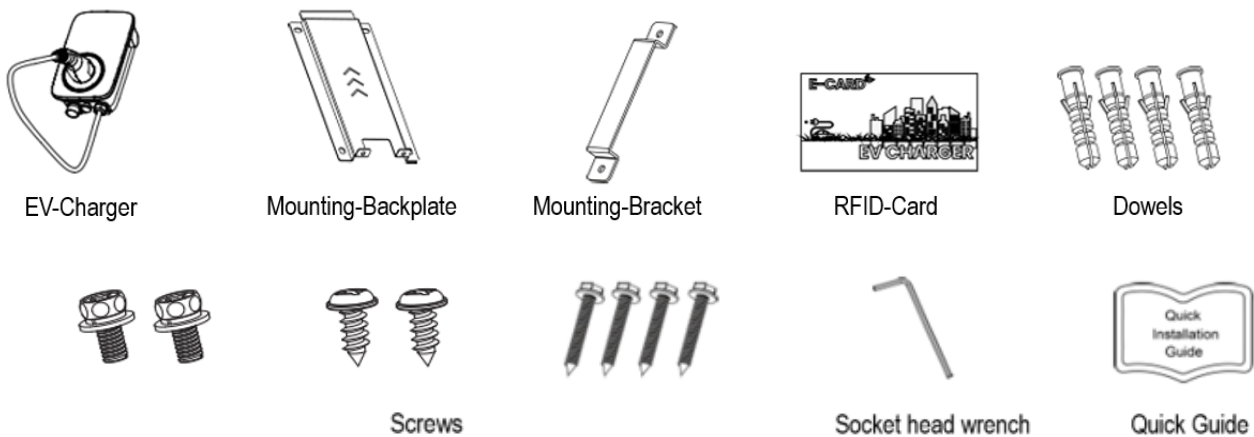

5.2. Mounting guidelines

Ensure that the installation location fulfils the following conditions:

- The installation location for the EV-Charger must be far away from water, flammable gases and corrosive substances.
- Ensure that the floor stand, or wall can withstand the weight of the EV-Charger.
- Not higher than approximately 2.000 meters above sea level
- Not in an environment with precipitation or high humidity (> 95%)
- Good ventilation conditions must be ensured:
 - The ambient temperature in the range of -25°C to + 50°C
- The Wall or column which the EV-Charger will be mounted must meet the following conditions:
 - A. The inclination of the Wall should be vertical or positive 15°:

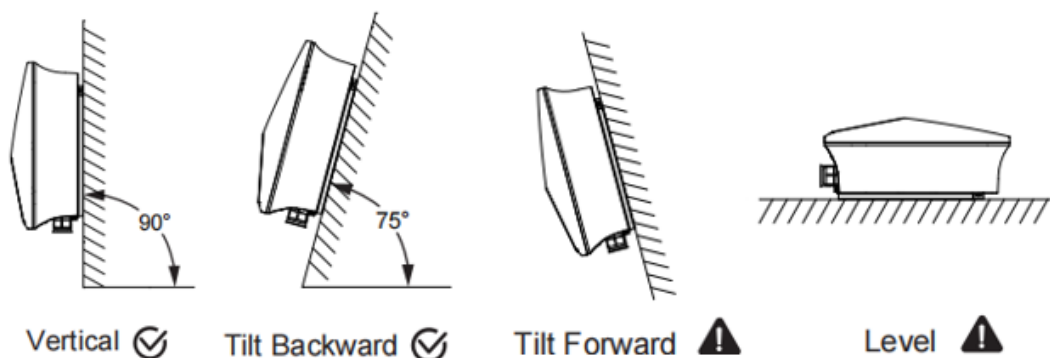

5.3. Required tools

The following tools are required to install the EV-Charger:

- Cross screwdriver
- Electric drill (with 8mm drill bit set)
- Crimping pliers
- Insulation stripping pliers



5.4. Assembly steps Wall Mounting

Step 1: Attach the Mounting-Backplate to the wall or floor column

- Select the location where you want to install the EV-Charger. Mark 4 holes according to the drilling template for the installation on the wall or floor column.

	<p>Danger! Before drilling, make sure that the water and electricity lines in the wall are not damaged at the installation site of the wall bracket to avoid hazards.</p>
---	--

- Drill the holes with an electric drill and make sure that the holes are at least 50mm deep and 8mm wide.

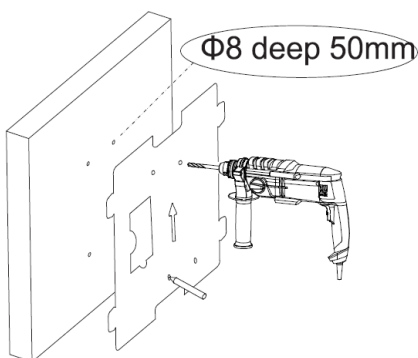

- Fit the supplied dowels (E) in the pre-drilled holes.

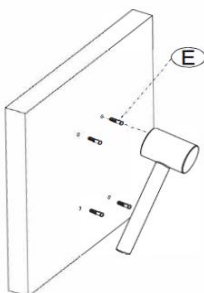

- Fit the mounting backplate (B) to the holes already prepared using the fixing screws (F) supplied.

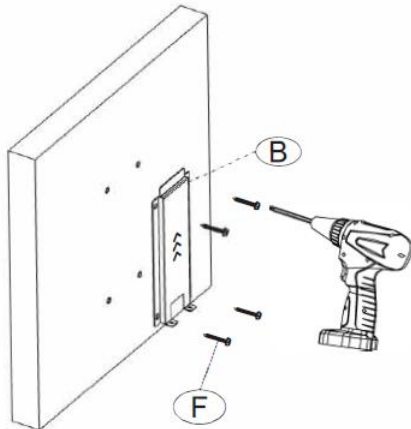

Step 2: Hang the EV-Charger on the mounting backplate

- Fit the mounting bracket (C) onto the EV-Charger using the screws (G) supplied.

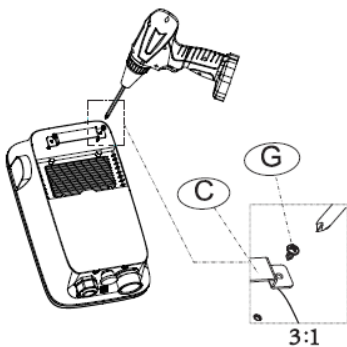

- Hang the EV-Charger into the Mounting backplate. Secure the EV-Charger by tighten the screws (H).

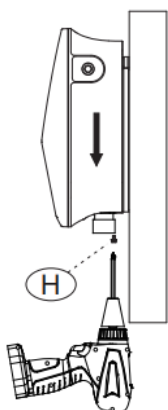

6. Electrical Connection

6.1. AC-Connection to the Grid

The NGEN STAR-EV7 series Charging Station are designed for single-phase grid connections. The voltage range is 230V \pm 20%, the frequency is 50/60Hz. Other technical requirements must comply with the requirements of the local public grid.

	<p>Warning! An RCD type A and a circuit breaker with at least 32A must be installed between the EV-Charger and the grid.</p>
---	---

Before you start installing the AC-Connection, disconnect the circuit breaker from all phases and secure it against reconnection!

Step 1: Stripping the AC-Cable

- Shorten the L, N and PE wire to 55 mm.
- Use the stripping pliers to cut 16 mm of the insulation from all wire ends as shown below:

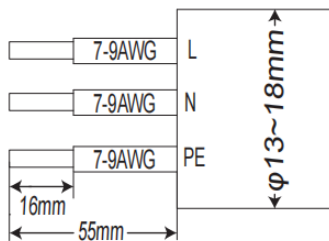

L: Brown wire
N: Blue wire
PE: Yellow & Green wire

Attention!
The permitted cable cross-section is:
6 - 10 mm².

	<p>Note! Please note the local cable type and colours for the actual installation. Before connecting the EV-Charger to the AC-Grid, check the grid voltage and compare it with the permissible voltage range (see technical data).</p>
---	---

Step 2: Connecting the AC-Cable to the EV-Charger:

- Use the crimping pliers to crimp the ferrules (G) onto the cable.

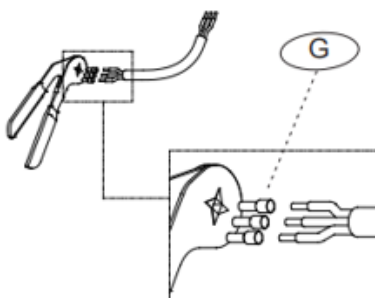

- Unscrew the union nut including the rubber seal from the charging station.

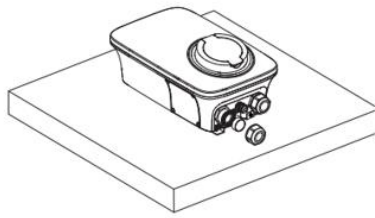

- Open the side cover and insert the cable into the charging station. (Wire diameter \varnothing 13-18mm). Ensure to slide the union nut and rubber seal onto the cable before inserting the cable into the EV-Charger.

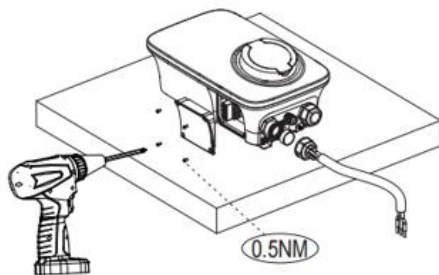

- Insert the wires into the Terminal strip and tighten them with a suitable screwdriver (screw torque 1.2 Nm). Pay attention to the correct positions (L/ N/PE). Do not forget to tighten the union nut on the charging station.

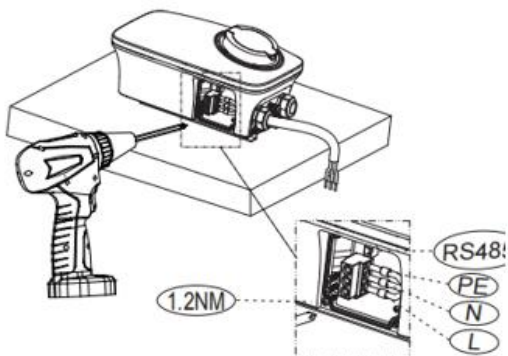

- Close the side cover and complete the installation (screw torque 0.5 Nm).

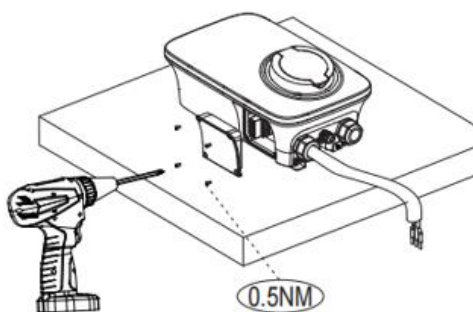

6.2. Communication-Connection

Step 1: Stripping the Communication-Cable

- Shorten the 485A and 485B wire to 15 mm.
- Use the stripping pliers to cut 8 mm of the insulation from all wire ends as shown below:

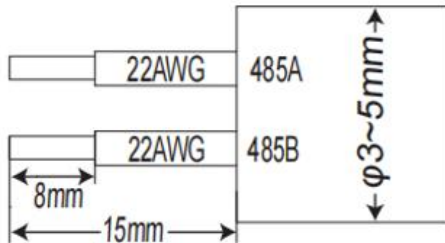

485A: Brown/Red/Green wire
485B: Blue/Black wire

Attention!
The permitted cable
cross-section is:
0.3 mm².



Note!
Please note the local cable type and colours for the actual installation.

Step 2: Connecting the Communication-Cable to the EV-Charger:

- Use the crimping pliers to crimp the ferrules (H) onto the cable.

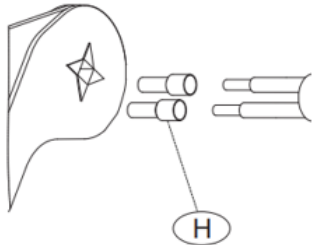

- Open the side cover and insert the cable into the charging station. (Wire diameter \varnothing 3-5mm).

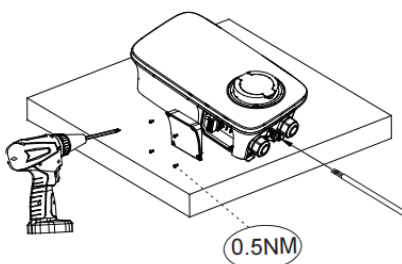

- Insert the wires into the Communication-Terminal and tighten them with a suitable screwdriver (screw torque 0.5 Nm). Pay attention to the correct positions (485A and 485B).

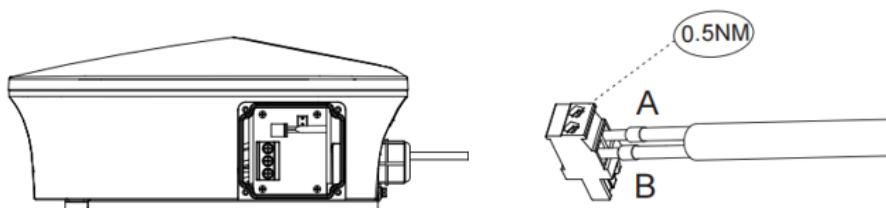

- Close the side cover and complete the installation (screw torque 0.5 Nm).

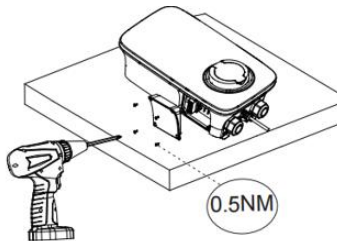

7. Energy Management

Photovoltaic Linkage:

The electric charging station can retrieve the power data from the inverter via the smart meter in real time and thus use the solar power efficiently. Two different modes can be set in the app for the intelligent use of photovoltaic energy:

- **Green Mode:** In green mode, the charging station is only activated when there is sufficient surplus energy from the photovoltaic system. No grid power is used to charge the electric car.
- **ECO-Mode:** In ECO mode, the surplus energy from the photovoltaic system is primarily used to charge the electric car. If the surplus energy is no longer sufficient, the charging station uses the grid power.

Load Balancing:

The electric charging station is able to retrieve the power data of household consumers in real time via the smart meter and adjust the charging current of all charging stations according to the current thresholds set in the app.

7.1. Electrical Connection for the Energy Management

In order to use the energy management functions (photovoltaic linking or load balancing) efficiently, a communication link between the smart meter and the electric charging station is always necessary. See the wiring diagram below:

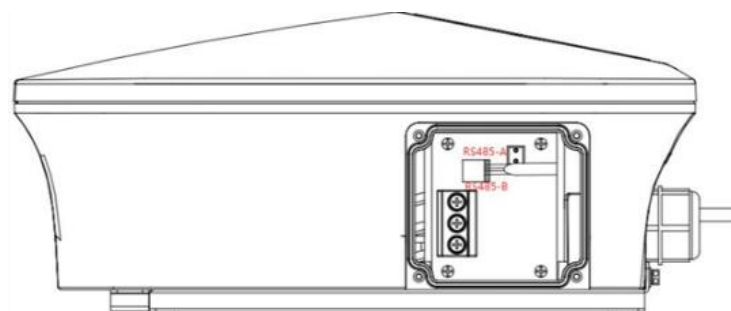
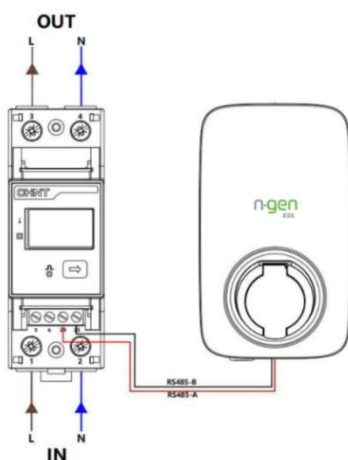

Note!

The load balancing function can also be used for several charging stations at the same time. In this case, the smart meter only needs to be connected to the master station. The activation of this function can be found in the commissioning manual.

8. Operation

8.1. Charging Mode and Operation

The user can set three charging modes via the app interface: Controlled, Locked, Plug & Charge.

8.1.1. Controlled Mode

Start or end the charging process with the APP or by using the RFID card. The app can also be used to reserve a charging station.

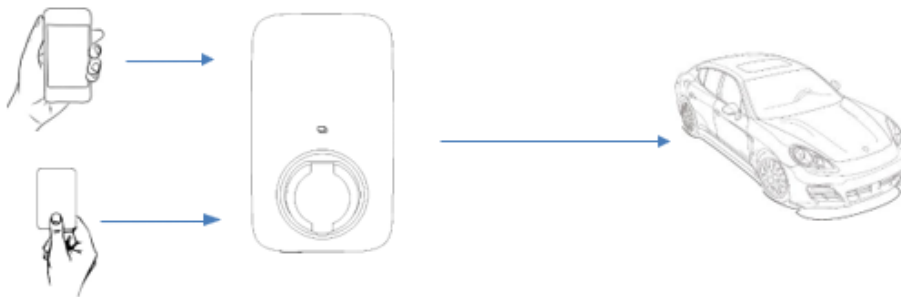

Step 1: Start Charging in the controlled mode with the App or RFID-Card

1. Set the EV-Charger to the Controlled mode inside the App.
2. Insert the charging plug into the electric vehicle.
3. Click on „Start“in the app or use the RFID-Card to start the charging process
4. Wait for authorizing.
5. Charging session is started.

Step 2: Stop Charging in the controlled mode with the App or RFID-Card

1. Click on „Stop“in the app or use the RFID-Card to end the charging process
2. Charging session end

8.1.2. Locked Mode

In this operating mode, the EV-Charger is locked and cannot be used.

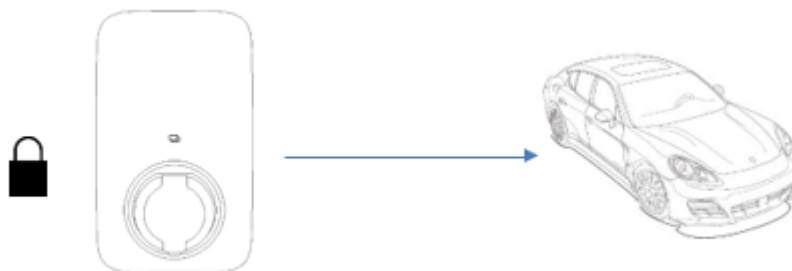

8.1.3. Plug & Charge Mode

The charging process starts automatically after the electric vehicle has been connected to the charging station. If the charging process needs to be stopped, the stop button on the side of the EV-Charger must be pressed.

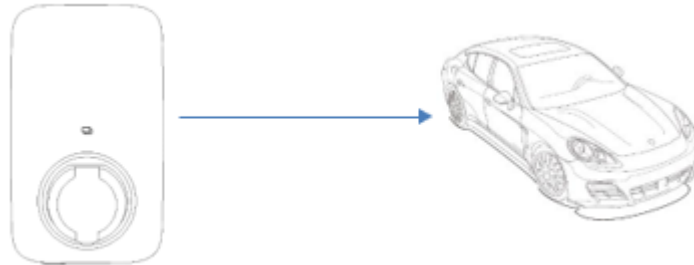

Step 1: Start Charging in the Plug & Charge Mode

1. Set the EV-Charger to the Plug & Charge Mode on the app.
2. Insert the charging plug into the electric vehicle.
3. Charging session is started.

Step 2: Stop Charging in the Plug & Charge Mode

1. Press the stop button on the side of the EV-Charger



Note!

For more information on setting up and using the app, please read the user manual.

8.2. Charger Status Indicators

LED Indicator Description	Definition
Green Flashing	Charging Station is available
Blue Steady	Electric vehicle is connected, User not authorized
Blue Flashing	Authorized, Wait for charging
Blue circular running light	Charging
Blue Flashing	Charging suspension
Green Steady	Charging Finish, wait for unplug
Yellow Steady	Charging Locking
Red Steady	Charging Station Fault

9. Maintenance

In the event of an error at the charging station, you can check the error information directly via the APP or using the flashing light on the charging station. Below you will find possible alarm messages and suggested solutions.

No.	Definition	Solution
1	Electronic lock fault	Set the electronic lock status to the correct position. If the EV-Charger does not return to normal operation, contact the manufacturer.
2	Emergency stop fault	Reset the emergency stop button. If the EV-Charger does not return to normal operation, contact the manufacturer.
3	Abnormal CP voltage	Contact the Manufacturer
4	Abnormal AC output contactor	Contact the Manufacturer
5	Over current	Reduce the output current. If the EV-Charger does not return to normal operation, contact the manufacturer.
6	Over voltage	Wait until the grid voltage is normal again. If the EV-Charger does not return to normal operation, contact the manufacturer.
7	Under voltage	Wait until the grid voltage is normal again. If the EV-Charger does not return to normal operation, contact the manufacturer.
8	Electric leakage	Contact the Manufacturer
9	Reverse connection of Line N	Connect the L and N wires correctly. If the EV-Charger does not return to normal operation, contact the manufacturer.
10	Abnormal frequency	Wait until the frequency is normal again. If the EV-Charger does not return to normal operation, contact the manufacturer.
11	Over temperature of charging interface	Wait until the temperature is normal again. If the EV-Charger does not return to normal operation, contact the manufacturer.

10. Shutdown

10.1. Dismantling the EV-Charger



Warning!
Before you start dismantling the AC connection, disconnect the circuit breaker from all phases and secure it against being switched on again!

- Disconnect the electric charging station from the AC input.
- Disconnect the communication and optional connection wirings. Remove the electric charging station from the mounting bracket.
- Remove the mounting backplate if necessary.

10.2. Packaging

If possible, please pack the EV-Charger in the original packaging. If the original packaging is no longer available, you can also use equivalent packaging that meets the following requirements.

- Suitable for loads of more than 10kg.
- Includes a carrying handle.
- Can be completely closed.

10.3. Storage and Transport

Store the electric charging station in a dry place where the ambient temperature is always between -25°C and +50°C. Ensure that the EV-Chargers are not stacked more than four boxes high during storage and transportation. If the charging Station or other associated components need to be disposed of, please ensure that this is done in accordance with local regulations for waste disposal. Ensure that each EV-Charger that is to be discarded is delivered to a location suitable for the disposal of this type of waste, in compliance with applicable regulations.

The copyright of this manual belongs to NGEN d.o.o. No legal or physical person may copy this manual, either in part or in full (including software), nor is any distribution or reproduction of the manual in any form or manner permitted. All rights reserved by NGEN d.o.o., Moste 101, 4274 Žirovnica, Slovenia. www.NGEN.si