

# **NGEN STAR H3**

## **USER MANUAL**

A HYBRID SYSTEM COMPRISING A PHOTOVOLTAIC SYSTEM AND AN ENERGY  
STORAGE SYSTEM

# 1 TABLE OF CONTENTS

2	Introduction.....	4
2.1	Scope of delivery.....	4
3	SAFETY INSTRUCTIONS.....	4
3.1	Working with electricity.....	4
3.2	Protection from the weather.....	4
3.3	Overloading the system.....	4
4	fire safety.....	4
4.1	Fire prevention.....	4
4.2	Actions in the event of a fire.....	5
5	INSTALLATION OF THE PHOTOVOLTAIC MODULES.....	5
5.1	Selecting the roof surface.....	5
5.2	Installation of photovoltaic modules.....	5
6	INSTALLATION OF THE ENERGY STORAGE SYSTEM.....	6
6.1	Selecting the location.....	6
6.2	Installing and connecting the energy storage system.....	6
7	INSTALLING THE INVERTER.....	6
7.1	Selecting the location.....	6
7.2	Mounting and connecting the inverter.....	6
8	OPERATING THE SYSTEM.....	6
8.1	Use of the stored energy.....	6
8.2	Monitoring the system performance.....	6
9	NGEN MOBILE APP FOR MONITORING AND MANAGEMENT.....	7
9.1	Overview.....	7
9.2	Installing the app.....	7
9.3	Registration and login.....	7
9.4	Using the app.....	8
9.5	Overview of energy production:.....	8
9.6	Energy.....	9
9.7	Battery settings.....	9
9.8	Support and application updates.....	10
10	INTEGRATION OF EXTERNAL DEVICES AND SYSTEMS.....	10
10.1	Smart home.....	10
10.2	Electric vehicles.....	10
10.3	External power generator.....	11
11	ENERGY INDEPENDENCE AND SELF-SUFFICIENCY.....	12
11.1	Energy independence.....	12
11.2	Self-sufficiency and sustainability.....	12

12	SYSTEM PROTECTION .....	12
12.1	Protection against theft and vandalism .....	12
12.2	Protection against weather damage .....	12
13	SYSTEM EXPANSION .....	12
13.1	Installing additional photovoltaic modules.....	12
13.2	Installing additional energy storage units .....	12
14	EMERGENCY POWER SUPPLY WITH A HYBRID SYSTEM.....	13
14.1	Backup power mode .....	13
14.2	Setting up the emergency power supply .....	13
14.3	Monitoring the emergency power supply .....	13
14.4	Restoring grid operation .....	13
15	NOTES ON THE USE OF THE EMERGENCY POWER SUPPLY.....	13
15.1	General information.....	13
15.2	Power in emergency power mode .....	13
15.3	Connecting the emergency power consumers to the EPS connection of the inverter .....	14
16	NGEN STAR SYSTEM SHUTDOWN .....	15
16.1	Emergency shutdown with EMERGENCY STOP switch .....	15
16.2	Switching off the NGEN STAR hybrid inverter.....	16
17	Synaptic-Unit – FunCtion of the relay outputs .....	18
17.1	Relay 1 – Boost Mode .....	18
17.2	Relay 2 – Load Reduction Mode .....	19
17.3	Relay 3 – Production Control .....	19
17.4	Activation of the relay control in the Smart Grid Connect App .....	20
18	Search for errors .....	21
18.1	Problems with data tracking in the "Smart Grid Connect" application .....	21
18.2	Problems with the NGEN STAR system.....	22
19	MAINTENANCE AND CLEANING.....	23
19.1	Regular maintenance .....	23
19.2	Cleaning of the PV modules .....	23
19.3	Checking and replacing batteries .....	23
20	RECYCLING AND DISPOSAL .....	23
20.1	Recycling old components .....	23
20.2	Disposal of the battery.....	23
21	ADDITIONAL INFORMATION AND SOURCES .....	23
22	WARRANTY AND SUPPORT .....	23
22.1	Contacting the manufacturer (NGEN).....	24

## 2 INTRODUCTION

The NGEN STAR H3 series is a hybrid inverter that converts solar energy into alternating current and can store energy in a battery storage system. This inverter is ideal for use in residential, commercial, and industrial buildings.

### 2.1 Scope of delivery

- NGEN-STAR Energy Storage System
- NGEN-STAR-H3 Hybrid Inverter
- Mounting materials
- Smart Box
- User Manual and Installation Instructions

## 3 SAFETY INSTRUCTIONS

### 3.1 Working with electricity

Always observe the safety precautions when working with electricity. Before you start installing and maintaining the system, make sure that the device is switched off and consult a qualified electrician. In the event of an emergency shutdown, the appliance has a Shutdown switch on the front of the Smart Box. By pressing the shutdown switch, the whole operation of the inverter stops, including the emergency power supply from the hybrid system with an electrical energy storage. If the Smart Box is used in combination with TIGO optimizers, the shutdown switch will also turn them off.

### 3.2 Protection from the weather

The installation of photovoltaic modules, energy storage systems and inverters require protective measures to protect them from water, snow, ice and other potential hazards. In addition, the system must be protected against lightning strikes.

### 3.3 Overloading the system

To prevent the system from being overloaded, monitor the energy consumption carefully. The system is designed for a specific output, so you should not add any additional loads without first consulting a qualified electrician.

## 4 FIRE SAFETY

### 4.1 Fire prevention

When installing and using the NGEN-Star hybrid system, it is essential to ensure fire safety. Both the system and its components are designed to minimize the risk of fire. However, it is essential to follow the guidelines below:

- **Installation:** Ensure that all system components, including photovoltaic modules, inverters, and energy storage systems, are installed in accordance with the manufacturer's instructions and local regulations.

- **Regular maintenance:** Carry out regular checks of the system and its components to detect signs of overheating, damage, or leaks.
- **Space requirements:** Make sure to maintain an appropriate distance between the system components and other devices to avoid overheating. The minimum space requirements can be found in the installation instructions for the respective devices.
- **Overloading the system:** Observe the technical limits of the system to avoid overloading the components.
- **Use of the safety functions:** Use EMERGENCY STOP switches such as the safety switch on the Smart Box, if necessary, to avoid potential hazards associated with electrical energy.

## 4.2 Actions in the event of a fire

If you notice smoke, sparks, fire or other signs of a fire, act immediately according to the following steps:

- **Pressing the EMERGENCY STOP switch:** If possible, press the shutdown switch on the Smart Box to stop the TIGO optimizers (if present) as well as the whole operation of the inverter, and thereby prevent further spread of the fire.
- **Using a fire extinguisher:** Try to fight the fire with a fire extinguisher that is suitable for electrical fires, such as a CO2 fire extinguisher.
- **Get to safety:** If you are unable to extinguish the fire, get to safety and inform other people in the vicinity of the danger.
- **Making an emergency call:** Call the fire department immediately and inform them of the situation. Specifically state that it is an electrical fire in connection with a photovoltaic system and an energy storage system.
- **Contact the manufacturer:** After a fire, please contact NGEN or an authorized service partner directly to check the condition of the system, determine possible causes and carry out the necessary repairs or replacement.

## 5 INSTALLATION OF THE PHOTOVOLTAIC MODULES

### 5.1 Selecting the roof surface

Select a roof surface that ideally faces south and offers optimum solar radiation for the photovoltaic modules. Take particular care to ensure that the roof surface is not shaded, as shading can reduce the performance and energy yield of the photovoltaic modules.

### 5.2 Installation of photovoltaic modules

Install the photovoltaic modules on the selected roof surface using the mounting material supplied in accordance with the installation specifications approved by the substructure manufacturer. Ensure that the panels are securely fastened and correctly aligned to prevent damage and ensure maximum absorption of the sun's rays with optimum efficiency.

## **6 INSTALLATION OF THE ENERGY STORAGE SYSTEM**

### **6.1 Selecting the location**

For the installation of the energy storage system, please select a dry, cool and well-ventilated location that is protected from direct sunlight, rain and snow.

### **6.2 Installing and connecting the energy storage system**

Install the storage system on the floor in accordance with the manufacturer's instructions and securely fasten the battery storage system to the wall. Then connect the energy storage system to the inverter using the cables supplied.

## **7 INSTALLING THE INVERTER**

### **7.1 Selecting the location**

Select a dry, cool, and well-ventilated location for the inverter that is protected from direct sunlight, rain, and snow. Ideally, the inverter should be located close to the energy storage system and the photovoltaic modules.

### **7.2 Mounting and connecting the inverter**

Mount the inverter on a solid wall in accordance with the manufacturer's instructions. Connect the inverter to the photovoltaic modules, the energy storage system, and the power grid. For detailed information on mounting and connecting the inverter, please refer to the device installation manual.

## **8 OPERATING THE SYSTEM**

### **8.1 Use of the stored energy**

The system automatically uses the energy stored in the battery storage system to cover self-consumption in the household or in the event of a grid failure when the inverter switches to backup power mode.

### **8.2 Monitoring the system performance**

The NGEN STAR H3 inverter also offers a mobile user interface for real-time monitoring of the system performance. With this monitoring interface, production data, energy consumption, battery status and any problems that may occur can be checked and read out via smartphone, tablet, or computer.

## 9 NGEN MOBILE APP FOR MONITORING AND MANAGEMENT

### 9.1 Overview

NGEN has developed a mobile app called Smart Grid Connect that allows users to monitor and manage their NGEN-Star system. The app provides features to monitor energy production and consumption, check battery status, manage system settings, and receive notifications of potential issues.



Figure 1: Smart Grid Connect-Application

### 9.2 Installing the app

The Smart Grid Connect mobile app is available to download from the Google Play Store (for Android devices) or the App Store (for iOS devices). Search for "Smart Grid Connect" in the App Store and follow the installation instructions.



### 9.3 Registration and login

Registration with a valid e-mail address and password is required to use the app for the first time. After registering, you will receive an email with a link to confirm your account. Follow the instructions in the email to complete the registration process.

## 9.4 Using the app

The Smart Grid Connect mobile app allows you to monitor and manage your NGEN-Star system in the following ways:

- **Overview of energy generation:** Monitor the energy production of the photovoltaic modules in real time.
- **Overview of energy consumption:** Keep an eye on the energy consumption in your household.
- **Battery status:** Check the current charging status of the energy storage system.
- **System settings:** Adjust the system settings, such as the battery's charge and discharge limits, the operating mode, the control of intelligent devices, or other settings, to increase system efficiency and reduce energy costs.
- **Notifications:** Receive notifications about possible system problems or maintenance reminders.

Colour indicators for the inverter status:

- Green: Normal system operation.
- Gray: The inverter is operating in off-grid mode.
- Orange: The inverter is in test mode.
- Red: The inverter has an error.

## 9.5 Overview of energy production:



Figure 2: Smart Grid Connect-overview

## 9.6 Energy

Under the "Energy" menu item, you will find a total of four graphs with the following meanings:

- Graph one, shows the energy consumption in the household (see Figure 3).
- Graph two, shows the energy production of the photovoltaic system (see Figure 4).
- Graph three, shows the state of charge of the battery (see Figure 5).
- Graph four, shows the imported or exported energy from the grid (see Figure 6).

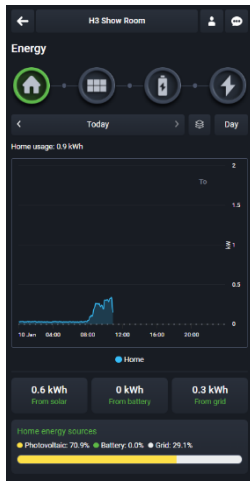

Figure 3: Energy consumption

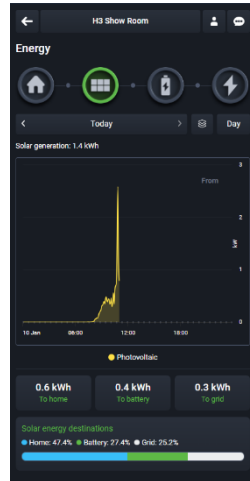

Figure 4: Produced energy

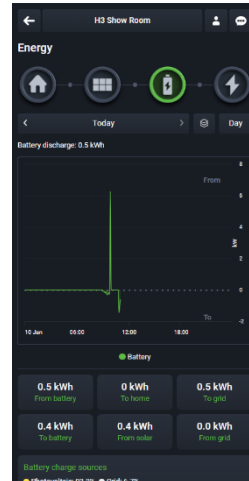

Figure 5: State of charge



Figure 6: Drawn energy from grid

## 9.7 Battery settings

In the battery settings, you can set the final charge limit of the battery and the charging and discharging modes that suit you (see Figure 7 and 8).



Figure 7: Battery settings

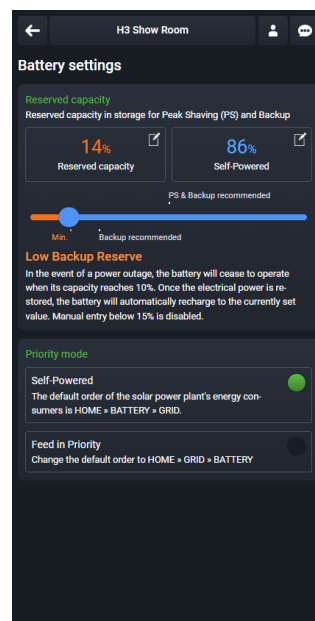

Figure 8: Battery settings

## 9.8 Support and application updates

For technical support of the Smart Grid Connect mobile app, please contact us directly through the application. To do this, navigate to the main screen, select „Support“, and then choose "Contact us" (see Figure 9 and 10). Alternatively, if you require immediate assistance, you can use our integrated chatbot (see Figure 11). If this is not possible, please contact us at support@ngen.si.

Remember to regularly check the app updates in the App Store to ensure that you can benefit from the latest features and improvements.



Figure 9: Support

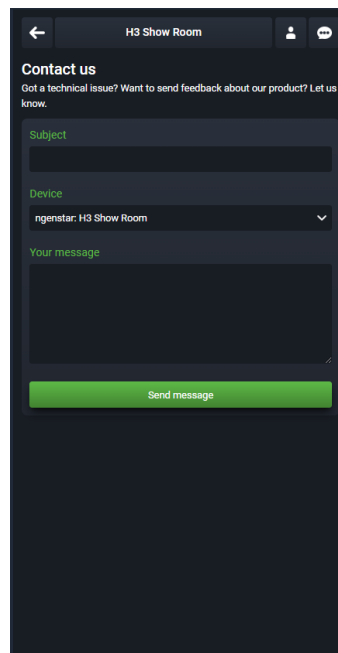

Figure 10: Contact us



Figure 11: Chatbot

## 10 INTEGRATION OF EXTERNAL DEVICES AND SYSTEMS

### 10.1 Smart home

The NGEN STAR system is compatible with most smart home solutions. By integrating it into your smart home system, energy consumption can be automated, and the system optimized. To successfully connect the NGEN-Star system to your smart home system, please follow the instructions provided by the manufacturer of your smart home device.

### 10.2 Electric vehicles

If you have an electric vehicle, the NGEN-Star system offers you the option of charging your vehicle with solar energy generated by a photovoltaic system. Simply connect your electric charging station to the NGEN-Star system, set the charging times in the mobile app and enjoy free and environmentally friendly energy for your electric vehicle.

### 10.3 External power generator

The connection and use of a generator is prohibited if it is part of the same circuit as the inverter. The permitted use is shown below in Figure 12.

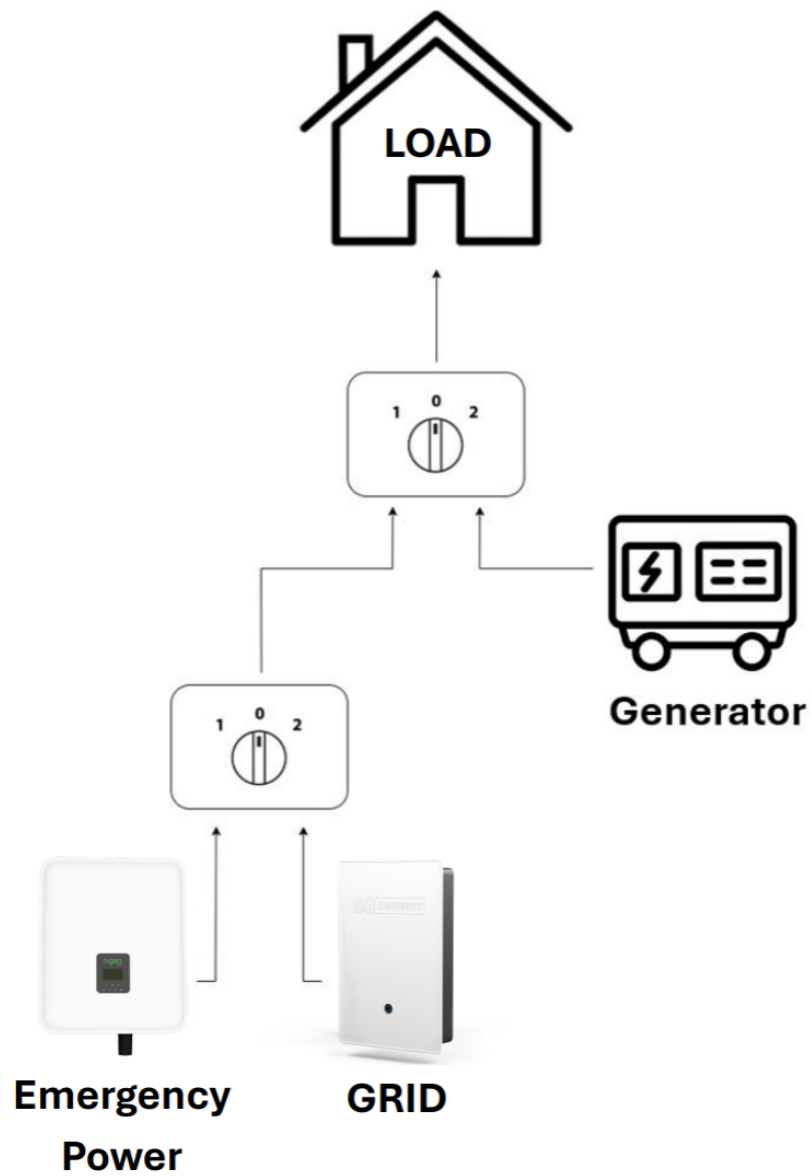

Figure 12: Connecting the generator

## **11 ENERGY INDEPENDENCE AND SELF-SUFFICIENCY**

### **11.1 Energy independence**

The NGEN-Star system offers you the opportunity to become energy self-sufficient and reduce or even eliminate your dependence on the power grid. Take the next step towards energy independence by monitoring your energy consumption, optimizing the operation of the system, and integrating additional photovoltaic modules or storage if required.

### **11.2 Self-sufficiency and sustainability**

By using the NGEN-Star system, you not only save money on your electricity bills, but you also make a major contribution to a sustainable and environmentally friendly lifestyle. The photovoltaic system is a renewable energy source that produces no greenhouse gas emissions and consumes no valuable natural resources.

## **12 SYSTEM PROTECTION**

### **12.1 Protection against theft and vandalism**

To provide your NGEN-Star system with additional protection against theft or vandalism, we recommend that you take out insurance to cover such events. Please contact your insurance agent for more information on insurance options.

### **12.2 Protection against weather damage**

In addition to the proper installation and maintenance of your system, we recommend that you take out insurance to cover possible damage caused by natural disasters such as storms, hail, or flooding. Please contact your insurance agent to determine if your current policy covers your system or if you need additional insurance.

## **13 SYSTEM EXPANSION**

### **13.1 Installing additional photovoltaic modules**

If you want to increase the energy generation capacity, it is possible to add additional photovoltaic modules to your existing system. Before installing new modules, make sure that your inverter is designed for this expansion and consult a qualified electrician for detailed advice.

### **13.2 Installing additional energy storage units**

If you want to increase the energy storage capacity, you can add additional energy storage units to your existing energy storage system. Before installing new storage units, make sure that your inverter is designed for this expansion and consult a qualified electrician for detailed advice.

## 14 EMERGENCY POWER SUPPLY WITH A HYBRID SYSTEM

### 14.1 Backup power mode

The NGEN-Star hybrid system provides your home or business with a reliable backup power supply in the event of power outages or unstable grids. In the event of a power failure, the system automatically switches to backup power mode and supplies important loads with the stored energy from the battery.

### 14.2 Setting up the emergency power supply

With the Smart Grid Connect Mobile app, you have the option of monitoring the emergency power supply operation. Please note that the capacity of the battery determines how many loads you can supply with power and for how long. To extend the duration of the emergency power supply, we recommend that you switch on important consumers such as lighting, refrigerators and water heaters and deactivate unnecessary energy consumers.

### 14.3 Monitoring the emergency power supply

You can use the mobile app to monitor the operation of the system in backup power mode, including the battery status and energy consumption. Use this information to adjust your energy consumption and ensure optimum system operation in emergency situations.

### 14.4 Restoring grid operation

Once the grid voltage has been restored, the NGEN-Star system automatically switches back to grid-connected mode and starts charging the battery. Please ensure that the mains power is stable before switching on devices that were switched off during the power failure.

## 15 NOTES ON THE USE OF THE EMERGENCY POWER SUPPLY

### 15.1 General information

EPS (Emergency Power Supply) is a system that provides power in the event of a power failure or interruption. Its main function is to ensure reliable and uninterrupted operation of critical devices and systems even during a power failure. In the NGEN-Star system, this is referred to as emergency power supply.

### 15.2 Power in emergency power mode

**It is important to consider the maximum permissible power of the system in backup power mode. This always depends on the inverter type:**

- **STAR-H3-12.0-E→3x22 A** This means that the maximum current in emergency power mode of the connected loads is limited to 22A per phase.

Please check the power and currents of all loads in the household that you wish to use during emergency power supply operation. Make sure that these do not exceed the maximum power and currents of the inverter.

**RECOMMENDED CONSUMERS:**

- Refrigerators and freezers,
- Computers and internet routers,
- communication devices,
- lighting,
- other small consumers,

**WARNING!**

Connecting inductive loads such as electric motors, induction heaters and transformers requires particular care. Due to their characteristics, inductive loads have an increased inrush current when switched on, which can exceed the maximum load of the EPS system (max. 30% unbalanced load between the phases). This can lead to an overload and automatic shutdown of the inverter. It is therefore recommended that the current of the connected inductive loads is approximately 60% below the maximum permissible total current. This ensures safe operation of the system and prevents overloads and possible damage to the devices.

It is recommended that you ask the manufacturer of your appliances whether they are compatible with the technical specifications for emergency power operation. We also recommend that you commission a qualified electrician to connect your selected emergency power consumers to the EPS connection of the inverter.

**15.3 Connecting the emergency power consumers to the EPS connection of the inverter**

The EPS power supply, which is drawn from the NGEN STAR inverter, is connected to a changeover switch that has two positions - position 1 and position 2. This provides a seamless changeover between the two power supply modes in the event of a grid failure. In the event of a grid failure, the changeover switch must be switched from position 2 to position 1 to enable the EPS system to supply the emergency power consumers. In normal operating conditions (grid operation), the switch is in position 2. This makes it possible to switch off unsuitable emergency power consumers before manual switching in the event of a power failure. This ensures safe operation of the system and prevents overloads and possible damage to the loads. (see Figure 29)

## 16 NGEN STAR SYSTEM SHUTDOWN

### 16.1 Emergency shutdown with EMERGENCY STOP switch

The Shutdown switch which is located on the front of the "Smart Box" unit, enables to stop the TIGO optimizers (if present) as well as the whole operation of the inverter quickly and safely in emergencies or during maintenance work. Pressing the Shutdown switch (see Figure 13) minimizes the risk of electric shocks or other issues related to electrical energy sourced from the inverter.



*Figure 13: Shutdown switch*

Use the Shutdown switch in the following situations:

- Before starting maintenance work to stop the operation of the inverter.
- In the event of fire
- If a battery is defective
- In all other hazardous situations that require the system to be switched off immediately.

Wait a few seconds after pressing the Shutdown switch, disconnecting the fuse for the AC supply of the inverter, and turning off the DC switch on the inverter and the battery to ensure the system is fully de-energized before beginning work on the components.

To restart the system, press the Shutdown switch again and wait 5 minutes until the system has fully booted up. If you notice any problems or irregularities, please contact NGEN technical support via the Smart Grid Connect App or an authorized service partner.

## 16.2 Switching off the NGEN STAR hybrid inverter

Follow the steps below to switch off the NGEN STAR hybrid inverter:

1. Press the "Confirm" button on the inverter for 5 seconds to call up the "START/STOP" menu. Confirm the "STOP" selection again with the "Confirm" button and wait until the message "Switch off" appears on the inverter display. The switch-off procedure is shown in the following illustrations:



Figure 14: Inverter stop\_1.4.

5s



Figure 15: Inverter stop\_1.5.

1s



Figure 16: Inverter stop\_1.6.

2. Switch the DC switch on the underside of the inverter from "ON" to "OFF".



Figure 17: Deactivation of the photovoltaic direct current supply\_1.1

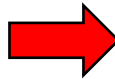

Figure 18: Deactivation of the photovoltaic direct current supply\_1.1

3. Press the silver "POWER" button on the battery (see Figure 19).

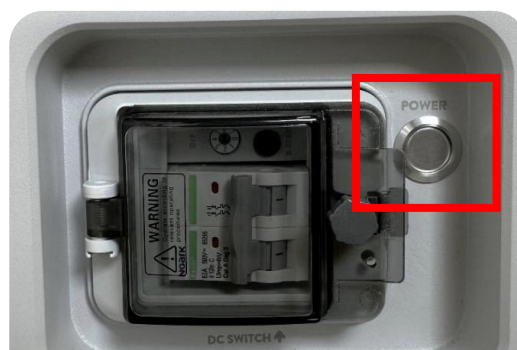

Figure 19: Switching off the battery.

4. Switch off the RCD and the supply fuse of the inverter with the designation "Inverter" in the Smart Box.

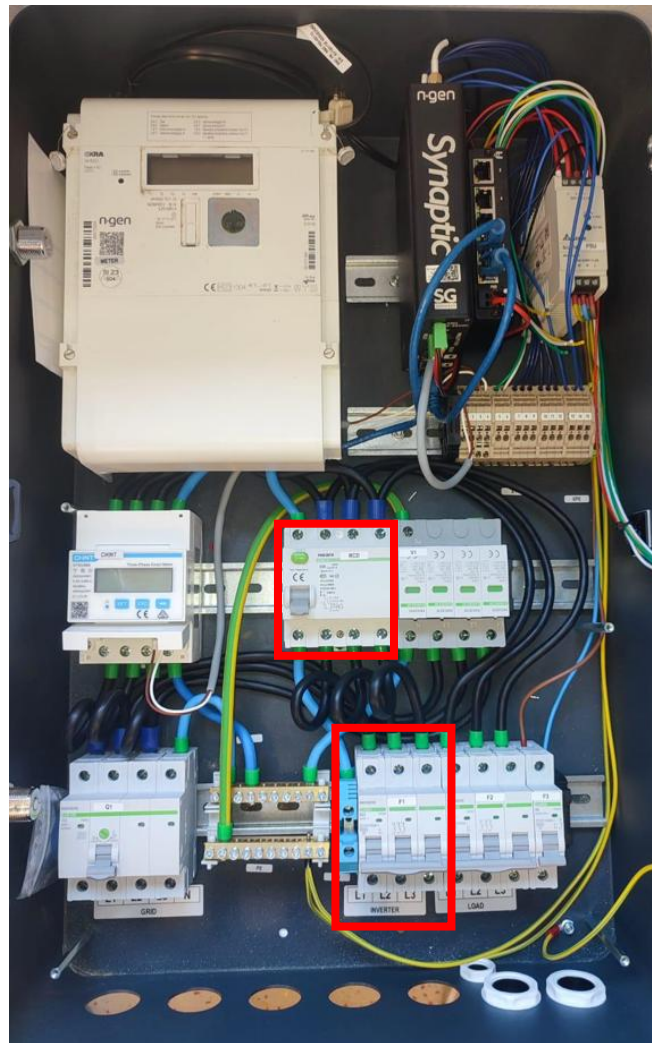

Figure 20: Switching off the Inverter fuse and RCD

If you notice any problems or irregularities, please do not hesitate to contact NGEN technical support via the application or an authorized service partner.

## 17 SYNAPTIC-UNIT – FUNCTION OF THE RELAY OUTPUTS

The Synaptic unit integrated into the Smart Box features three relay outputs to which various production and consumption units can be connected. The function explanations for each relay you can find below:

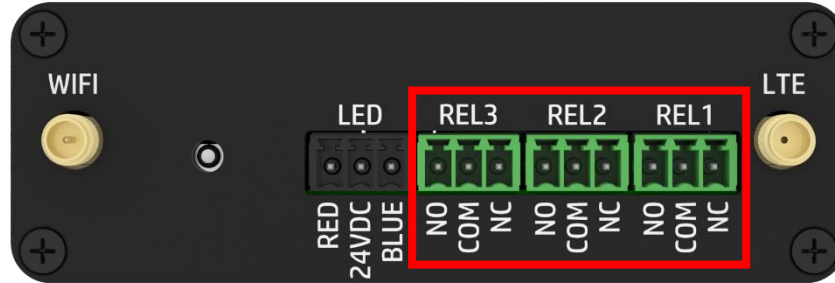
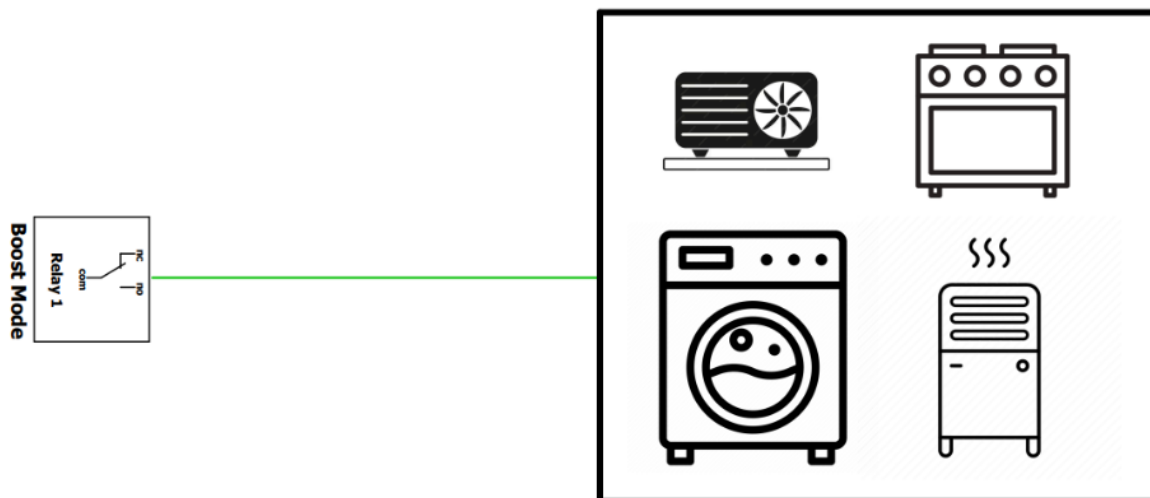

Figure 21: Free contacts for smart devices on the SYNAPTIC UNIT

### 17.1 Relay 1 – Boost Mode

The Boost Mode allows you to take advantage of periods of low-cost or free electricity for devices that can store energy in the form of heat or increase consumption at certain intervals. This feature is ideal for heat pumps, electric heaters, and electric vehicles, which you can use when electricity is cheaper or free. With the Boost Mode, you will reduce your costs and increase energy efficiency by using energy when it is most advantageous. Especially when surplus energy from a photovoltaic system is used to optimize self-consumption.



**How It Works:** Relay 1 is activated during intervals of reduced-price or free electricity.

**Configuration:** To enable this function, Relay 1 must be connected to your device so that the desired appliance turns on when the relay is activated. This allows automatic control of your device and maximizes the benefits of favourable electricity prices.

## 17.2 Relay 2 – Load Reduction Mode

The Load Reduction Mode is a feature that rewards you for energy-efficient behaviour. It encourages a reduction in electricity consumption by deactivating devices during times of high network load. This feature is ideal for devices such as heat pumps, electric heaters, and charging stations, which can be deactivated during periods when energy is expensive or when reducing consumption brings a reward.

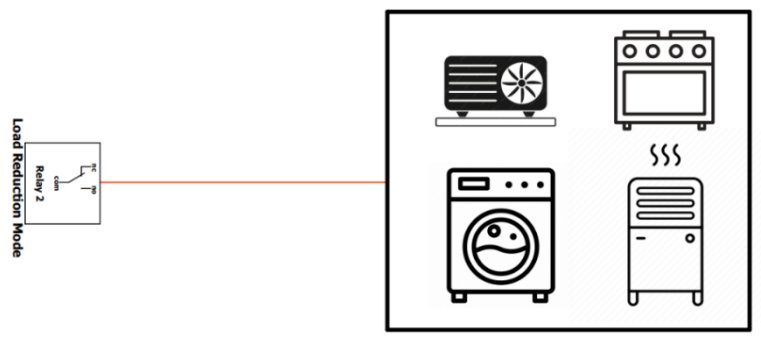

**How It Works:** Use devices connected to Load Reduction Mode (Relay 2) during these intervals to reduce your consumption. Receive a reward for participating in an energy-efficient program that helps stabilize the grid and reduce high network loads.

**Configuration:** To enable this function, Relay 2 must be connected to your device. When the relay is activated, your device will adjust to the optimal operating time, allowing you to save and earn rewards.

## 17.3 Relay 3 – Production Control

Production Control is a feature that helps you balance energy production and provides financial compensation for lost production. It is designed for users with solar power systems or other production units such as hydroelectric, wind or biomass plants that occasionally face disconnections or reduced production. With the Production Control, you can receive compensation for lost energy even when your system is not producing electricity for example during the activation of the negative tertiary reserves by the grid operator.

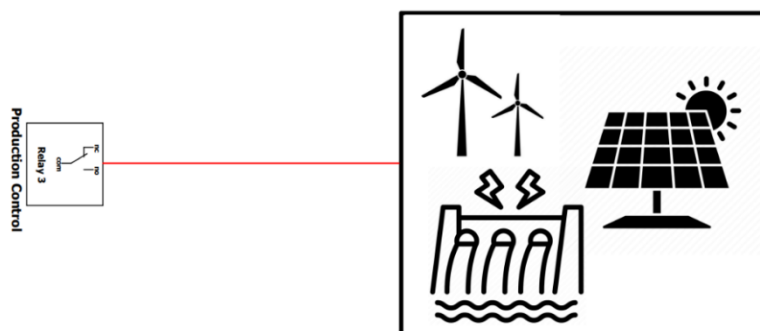

**How It Works:** In case of disconnections or reduced production, you receive simulated financial compensation for the lost energy.

**Configuration:** To enable this function, Relay 3 must be connected to your production unit, allowing monitoring and control of lost production. This way, you receive compensation and achieve a more stable return despite occasional interruptions.

### 17.4 Activation of the relay control in the Smart Grid Connect App

The user can set the "Relay Control" to "ACTIVE" or "INACTIVE" in the mobile app. Under the menu item Relay Control, you can perform the relay configuration. For all three relays, the user can define relay name and manually set time frames when the relay should be activated.



Figure 22: Menu Item Relay Control

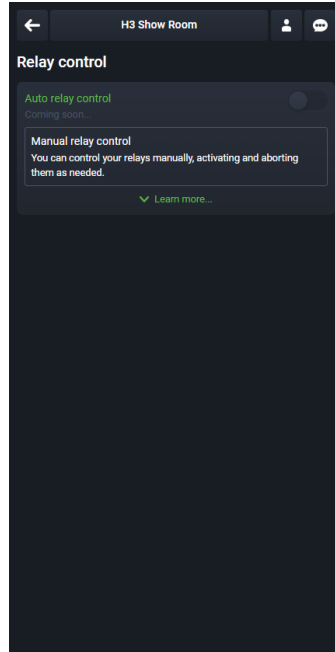

Figure 23: Relay Control Settings

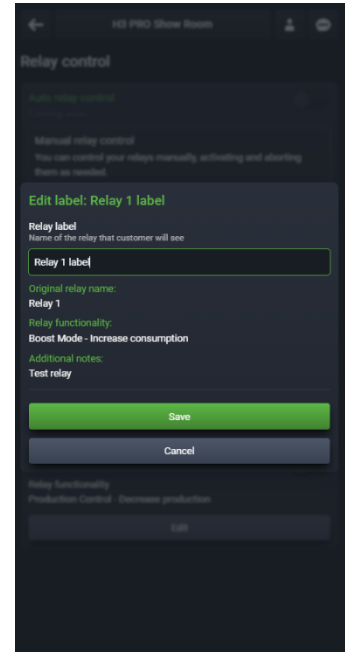

Figure 24: Edit Settings of the Relay

## 18 SEARCH FOR ERRORS

### 18.1 Problems with data tracking in the "Smart Grid Connect" application

1. If a communication problem occurs, as shown in Figure 25, please follow the steps below to solve the problem: Switch off the device (Internet router) responsible for the Internet connection and switch it on again after 10 seconds. Wait until your Internet connection is restored and then continue with the procedure. If your Internet is not working, please contact your Internet provider.

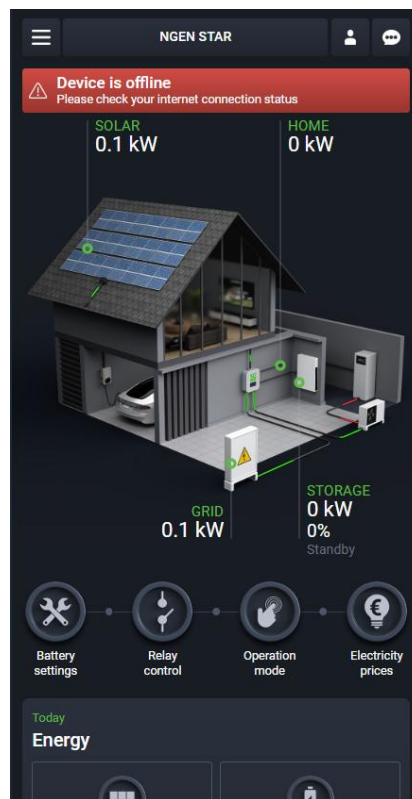

Figure 25: Problems with the communicator

2. If you still do not see any current data from your device or the communication is not correct, please contact an authorized service technician or our technical support via the application.

## 18.2 Problems with the NGEN STAR system

If your NGEN-Star system is not working properly or a fault occurs, press, and hold the "Confirm" button on the inverter until the "START/STOP" menu appears. Press the "Confirm" button again to switch off the inverter. If your system has an integrated transfer switch and you are actively using the EPS or backup function, please ensure that the switch is set to the [2] position so that the grid supplies your devices with power instead of the inverter (if in doubt, please refer to the EPS power supply instructions supplied with each inverter). The procedure described is shown in the illustrations below:



Figure 26: Inverter stop\_1.1.

5s

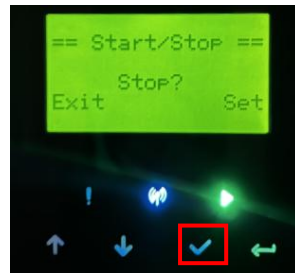

Figure 27: Inverter stop\_1.2.

1s



Figure 28: Inverter stop\_1.3.

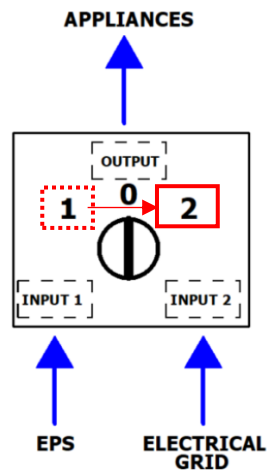

Figure 29: Changeover switch

For further assistance and troubleshooting, please contact your authorized service partner for your system or our technical support via the application.

## **19 MAINTENANCE AND CLEANING**

### **19.1 Regular maintenance**

To ensure the smooth operation of your NGEN-Star system, we recommend that you regularly check the condition of the system, including the photovoltaic modules, inverters, and energy storage units. To do this, follow the maintenance instructions described in the manual.

### **19.2 Cleaning of the PV modules**

Photovoltaic modules should be cleaned regularly to ensure a high level of efficiency. We recommend checking the modules at least once a quarter and cleaning them with clean water and a soft cloth if necessary. Avoid using aggressive cleaning agents or hard brushes, as these can damage the panels.

### **19.3 Checking and replacing batteries**

Energy storage systems are subject to natural wear and tear and may need to be replaced over time. We recommend checking the performance of the battery regularly and contacting the manufacturer or an authorized service partner if a replacement is required.

## **20 RECYCLING AND DISPOSAL**

### **20.1 Recycling old components**

Do not dispose of the system components with household waste at the end of their service life. Photovoltaic modules, energy storage units and inverters contain materials that can be recycled. Instructions for proper recycling can be obtained from your local recycling centre or directly from the manufacturer.

### **20.2 Disposal of the battery**

The batteries in the energy storage system can be hazardous to the environment if they are disposed of improperly. At the end of the battery's service life, contact your local recycling centre or the manufacturer for instructions on proper disposal.

## **21 ADDITIONAL INFORMATION AND SOURCES**

For more information on using, maintaining, and improving the NGEN-Star system, we recommend that you contact NGEN directly or visit the NGEN website. You can also research independent sources and forums to share experiences and tips with other NGEN-Star users.

## **22 WARRANTY AND SUPPORT**

The NGEN STAR-Star is covered by a limited warranty that covers defects in materials and workmanship. For more information about the warranty conditions, product registration and technical support, please contact the manufacturer NGEN directly.

## 22.1 Contacting the manufacturer (NGEN)

Further information about the NGEN-Star system and other NGEN products can be found on the manufacturer's website: <https://www.sgconnect.eu/en>.

Technical support / Complaints and warranty:

- For technical support or questions about the NGEN-Star system, please use the following support channels:
  - o Chatbot Inside Smart Grid Connect App (See Point 9.8)
  - o Support Function inside the Smart Grid Connect App (See Point 9.8)
  - o E-Mail: [support@ngen.si](mailto:support@ngen.si)
  
- For information about warranty, complaints, or product replacement, please use the support function of the Smart Grid Connect app to contact NGEN technical support (See Point 9.8).

The copyright of this manual belongs to NGEN d.o.o. No legal or physical person may copy this manual, either in part or in full (including software), nor is any distribution or reproduction of the manual in any form or manner permitted. All rights reserved by NGEN d.o.o., Moste 101, 4274 Žirovnica, Slovenia. [www.NGEN.si](http://www.NGEN.si)