

# INSTALLATION INSTRUCTION

## SMART METER

### TT3



## Table of Contents

1.	Hints for this Manual .....	3
1.1.	Range of Validity .....	3
1.2.	Target Group .....	3
1.3.	Used Symbols .....	3
2.	Use and Safety .....	4
2.1.	Proper Use of the Product .....	4
2.1.1.	Tasks of the Smart Meter TT3 .....	4
2.1.2.	Authorized network topologies.....	5
2.2.	Safety Instructions .....	5
3.	Technical Specifications.....	5
3.1.	Smart Meter TT3 .....	5
4.	Installation.....	6
4.1.	Scope of delivery .....	6
4.2.	Requirements for the installation location .....	6
5.	Electrical Connection.....	7
5.1.	Cable entries and fittings .....	7
5.2.	AC-Connection Diagram.....	8
5.3.	Communication-Connection Diagram.....	9
5.4.	Internet Connection .....	10
6.	Function of the Synaptic relay outputs .....	11
6.1.	Relay 1 – Boost Mode .....	11
6.2.	Relay 2 – Load Reduction Mode .....	12
6.3.	Relay 3 – Production Control .....	12
7.	Configuration of the Relais in the Smart Grid Connect App.....	13
8.	Button with LED Indicator .....	14
9.	Commissioning of the Smart Meter TT3 .....	14
9.1.	Requirements.....	14
9.2.	Start-up Steps.....	14
9.3.	Commissioning the Smart Meter TT3 with the SG-Connect APP.....	14
10.	Maintenance and Cleaning .....	19
10.1.	Cleaning the Smart Meter TT3 .....	19
11.	Storage.....	19
12.	Disposal.....	19
13.	Disposal.....	19

## ENGLISH

Read this installation instruction carefully before installation. Failure to do so may result in personal injury and damage to property or invalidate the warranty and product guarantee. Installation requires specialist knowledge and may therefore only be carried out by appropriately qualified and authorized specialists!

The general handling of the product, its use or the exact installation methods are beyond the control of NGEN. Therefore, NGEN cannot accept any responsibility for damages, losses or cost resulting from improper installation, improper handling of the incorrect use!

# 1. Hints for this Manual

## 1.1. Range of Validity

The document describes the installation, commissioning, and maintenance for the product:

Smart Meter TT3





Note: Please keep these instructions in a place where they are always accessible.

## 1.2. Target Group

This manual is intended for qualified electricians. The tasks described in this manual can only be performed by qualified electricians.

## 1.3. Used Symbols

The following types of safety instructions and general information appear in this document as described below:

	<p><b>Danger!</b> "Danger" indicates a hazardous situation which, if not avoided, will result in death or serious injury.</p>
	<p><b>Warning!</b> "Warning" indicates a hazardous situation which, if not avoided, could result in death or serious injury.</p>
	<p><b>Caution!</b> "Caution" indicates a hazardous situation which could result in minor or moderate injury if not avoided.</p>
	<p><b>Note!</b> "Note" provides important tips and instructions.</p>

This section explains the symbols shown on the type of plate:

	<p><b>CE labelling</b> The Smart Meter TT3 complies with the requirements of the applicable CE directives.</p>
	<p><b>Protection class IP54</b> The Smart Meter TT3 is fully protected against splashing water.</p>
	<p><b>Rated operating Voltage [V]</b> Do not operate the Smart Meter TT3 on any other mains voltage than that specified.</p>
	<p><b>Rated operating Frequency [Hz]</b> Do not operate the Smart Meter TT3 at any other operating frequency than specified.</p>
	<p><b>Peak-Current [A]</b> The Smart Meter TT3 may be operated up to this current.</p>
	<p><b>IEC/EN – Standard reference</b> The Smart Meter TT3 fulfils the requirements of: EN 61439-1 and EN61439-2</p>

## 2. Use and Safety

### 2.1. Proper Use of the Product

#### 2.1.1. Tasks of the Smart Meter TT3

- The Smart Meter TT3 is installed on the main entry point of the house with current transformers.
- The Smart Meter TT3 is used for households/industries with more than 63A on the main entry point in the house.
- Measurement and transmission of the parameters required for energy management and the SG-Connect App using the integrated smart meter.
- Controlling of intelligent devices (Heat pumps, Electric Heater or other SG-Ready compatible devices) for the energy management using the Synaptic Unit.
- Connection to the electricity grid for the use of dynamic prices from independent electricity providers or NGEN as an electricity provider.

### 2.1.2. Authorized network topologies

Grid Type	Description	Approved
TN(C)-S	Grid operator: 4 cores (PE and N together) Customer installation: 5 cores (separated PE and N)	YES
TN-S	Grid operator: 5 cores (separated PE and N) Customer installation: 5 cores (separated PE and N)	YES
TN-C	Grid operator: 4 cores (PE and N together) Customer installation: 4 cores (PE and N together)	YES

	<p>Note!</p> <p>The TT3 Smart Meter is measuring on the house node with current transformers. It is not possible to connect this version of smart meter directly to the grid.</p>
---	---

### 2.2. Safety Instructions

	<p>Danger!</p> <p><b>Danger to life due high voltages!</b></p> <p>The installation and commissioning of the Smart Meter TT3 may only be carried out by trained / certified electricians.</p>
---	--

## 3. Technical Specifications

### 3.1. Smart Meter TT3

Model	Smart Meter TT3
<b>ELECTRICAL SPECIFICATIONS</b>	
Rated Voltage on the house node [Un] [Vac]	3x 230 (Current Transformers)
Primary Current of the transformers [A]	Depends on the Amps of the main entry point
Secondary Current of the Transformers [A]	5
Rated Voltage power supply Communication [Un] [Vac]	1x 230
Rated Frequency [Hz]	50
<b>GENERAL DATA</b>	
Dimensions [H*W*D]	500 * 400 * 175
Protection	IP54
IEC/EN - Standard	EN 61439-1 & EN 61439-2

## 4. Installation

Before installing the device, make sure that the Smart Meter TT3 has not been damaged during transport. If there are visible damages, such as cracks, please contact the product seller immediately.

### 4.1. Scope of delivery

The delivery includes the pre-installed Smart Meter TT3 along with the corresponding installation and wiring instructions. Additionally, a pair of keys is provided to lock or unlock the Smart Meter TT3 as needed.

### 4.2. Requirements for the installation location

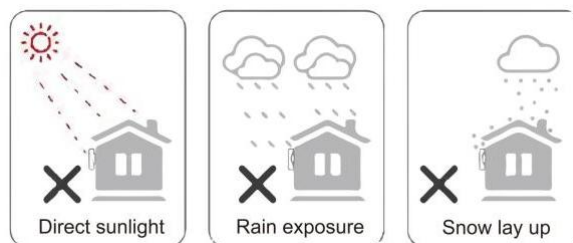

Ensure that the installation location fulfils the following conditions:

- The surface consists of solid materials
- The surface is suitable for the weight and dimensions
- The installation location is always accessible
- The installation location is not near to hot surfaces such as radiators or other appliances
- The installation location is not exposed to direct sunlight or rain
- The installation location is protected from splashing water
- The technical connection conditions of the grid operator are adhered to
- The installation location is not in potentially explosive areas
- The installation location is not in areas where highly flammable materials are stored
- Please avoid direct sunlight, rain and snow during installation and operation:



## 5. Electrical Connection

The Smart Meter TT3 are designed for three-phase grid with using current transformers for measurements on the house node. The voltage range is 220/230/240V, the frequency is 50/60Hz. Other technical requirements must comply with the requirements of the local public grid.

	<p><b>Warning!</b> Before you start with the electrical connection of the Smart Meter TT3, disconnect the main entry fuse of the house, the circuit breakers, and the RCD from all phases and secure it against reconnection!</p>
	<p><b>Note!</b> Please note the local cable type, cable cross-section, and colours for the actual installation. Before connecting the current transformers of the Smart Meter TT3, check the grid voltage and compare it with the permissible voltage range.</p>

### 5.1. Cable entries and fittings

Please use the pre-drilled holes on the underside of the Smart Meter TT3 for the cable entry.

	<p><b>Note!</b> The required cable fittings are not included in the delivery. Please use suitable cable fittings from the construction site that match the used cable cross-section.</p>
--	--

## 5.2. AC-Connection Diagram

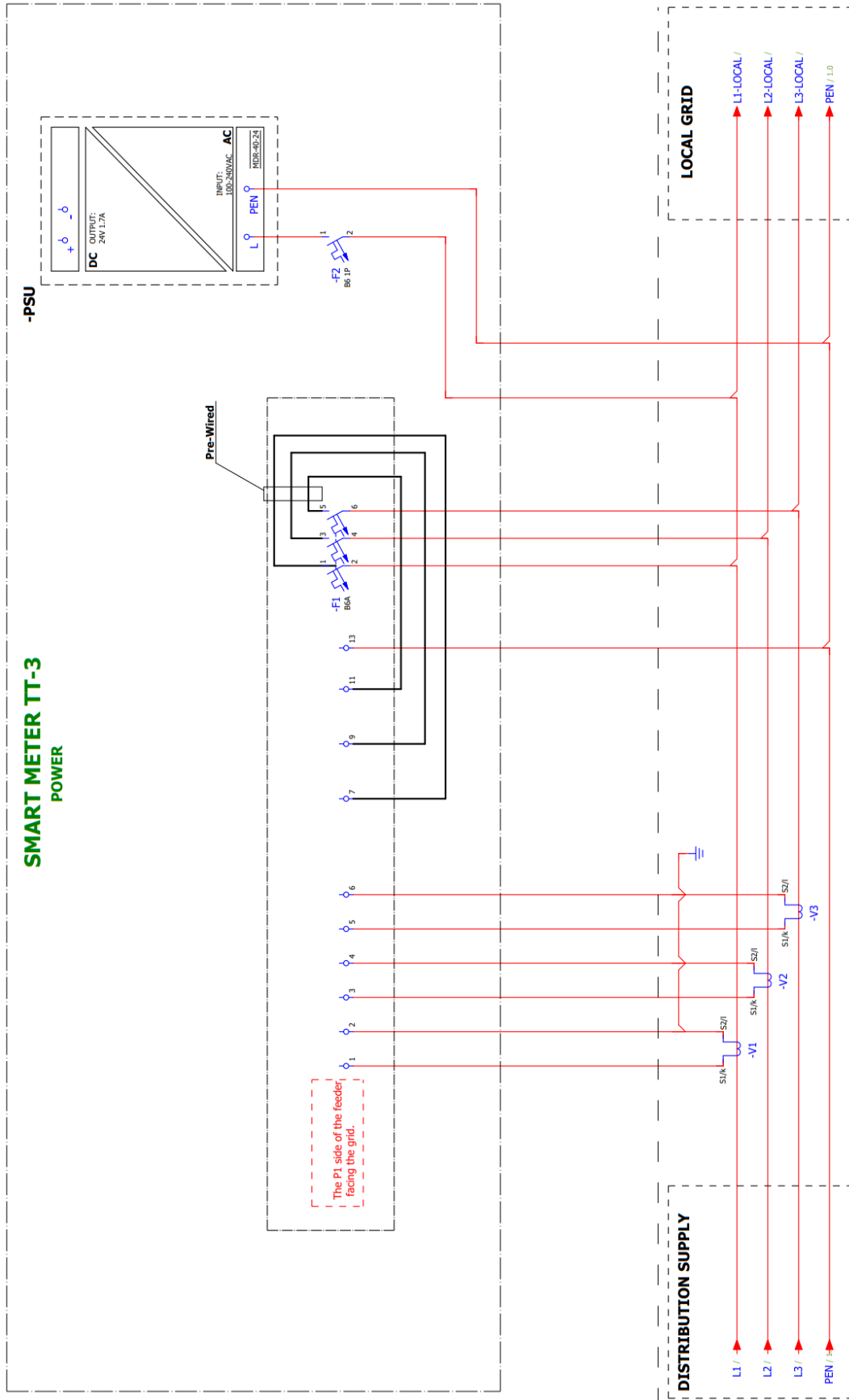

### 5.3. Communication-Connection Diagram

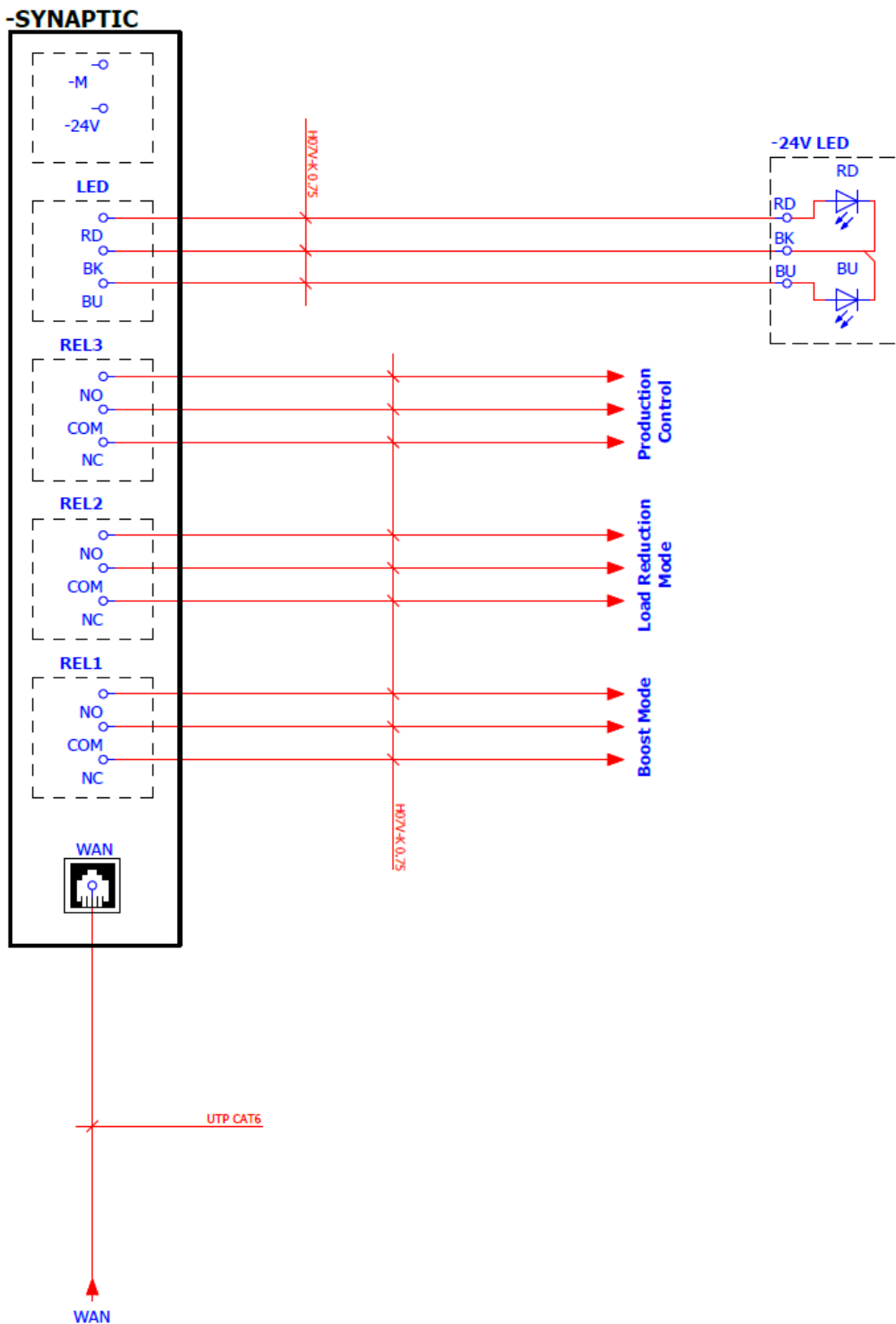

#### 5.4. Internet Connection

Connect the Synaptic unit of the Smart Meter TT3 to the customer's local internet router using an Ethernet cable. Connect the Ethernet cable from the internet router to the Synaptic unit as follows:

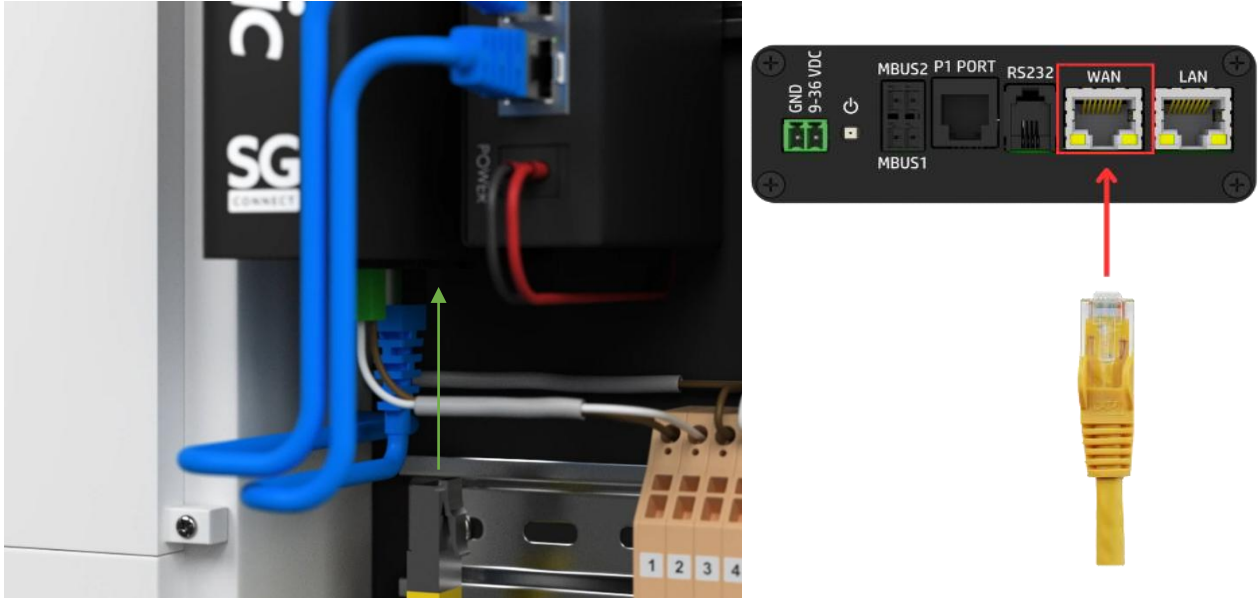

**Note!**  
The port on the Synaptic-Unit for the internet connection is labelled "WAN".

## 6. Function of the Synaptic relay outputs

For the connection of the relays as mentioned in section 6.3, please find below the explanations of the functions of each individual relay:

### 6.1. Relay 1 – Boost Mode

The Boost Mode allows you to take advantage of periods of low-cost or free electricity for devices that can store energy in the form of heat or increase consumption at certain intervals. This feature is ideal for heat pumps, electric heaters, and electric vehicles, which you can use when electricity is cheaper or free. With the Boost Mode, you will reduce your costs and increase energy efficiency by using energy when it is most advantageous. Especially when surplus energy from a photovoltaic system is used to optimize self-consumption.

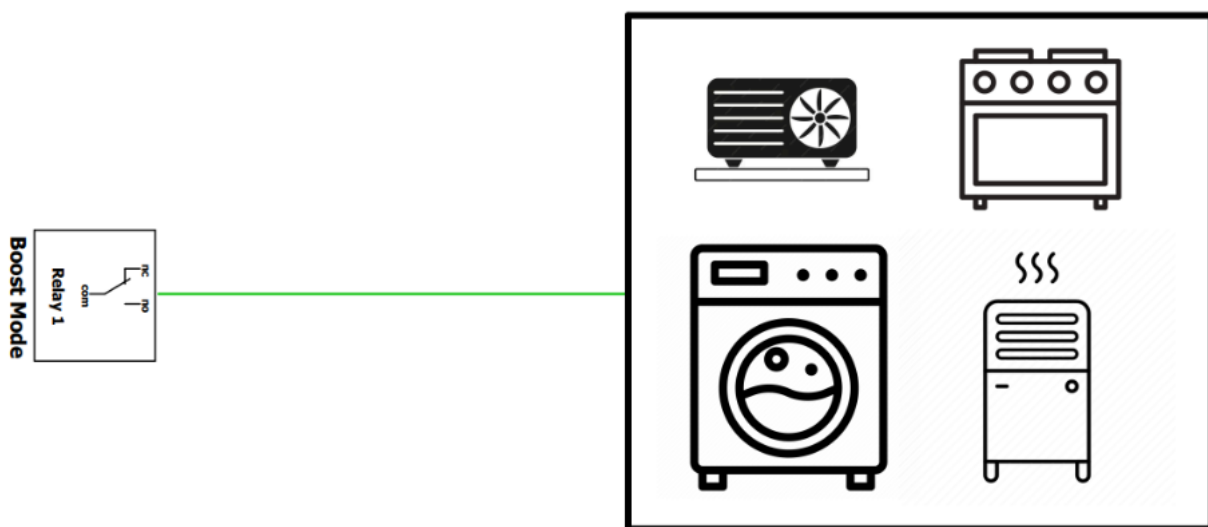

**How It Works:** Relay 1 is activated during intervals of reduced-price or free electricity.

**Configuration:** To enable this function, Relay 1 must be connected to your device so that the desired appliance turns on when the relay is activated. This allows automatic control of your device and maximizes the benefits of favourable electricity prices.

## 6.2. Relay 2 – Load Reduction Mode

The Load Reduction Mode is a feature that rewards you for energy-efficient behaviour. It encourages a reduction in electricity consumption by deactivating devices during times of high network load. This feature is ideal for devices such as heat pumps, electric heaters, and charging stations, which can be deactivated during periods when energy is expensive or when reducing consumption brings a reward.

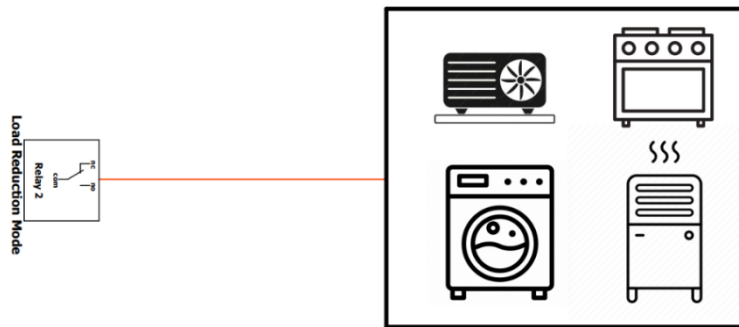

**How It Works:** Use devices connected to Load Reduction Mode (Relay 2) during these intervals to reduce your consumption. Receive a reward for participating in an energy-efficient program that helps stabilize the grid and reduce high network loads.

**Configuration:** To enable this function, Relay 2 must be connected to your device. When the relay is activated, your device will adjust to the optimal operating time, allowing you to save and earn rewards.

## 6.3. Relay 3 – Production Control

Production Control is a feature that helps you balance energy production and provides financial compensation for lost production. It is designed for users with solar power systems or other production units such as hydroelectric, wind or biomass plants that occasionally face disconnections or reduced production. With the Production Control, you can receive compensation for lost energy even when your system is not producing electricity for example during the activation of the negative tertiary reserves by the grid operator.

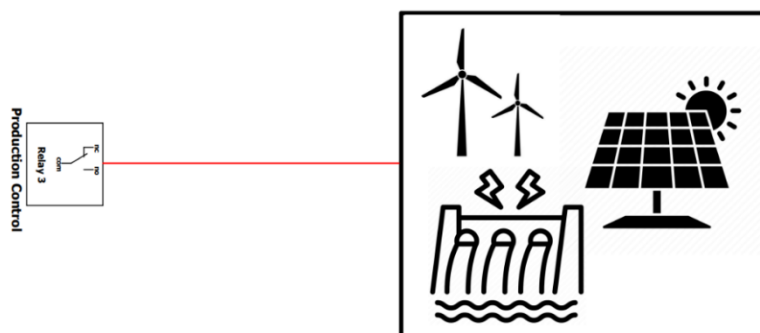

**How It Works:** In case of disconnections or reduced production, you receive simulated financial compensation for the lost energy.

**Configuration:** To enable this function, Relay 3 must be connected to your production unit, allowing monitoring and control of lost production. This way, you receive compensation and achieve a more stable return despite occasional interruptions.

## 7. Configuration of the Relais in the Smart Grid Connect App

After connecting the relay contacts to the intelligent devices, configuring the relays in the Smart Grid Connect app is necessary. Log in to the Smart Grid Connect app and open the desired system. Under the menu item Relay Control, you can perform the relay configuration. For all three relays, the user can define relay name and manually set time frames when the relay should be activated.

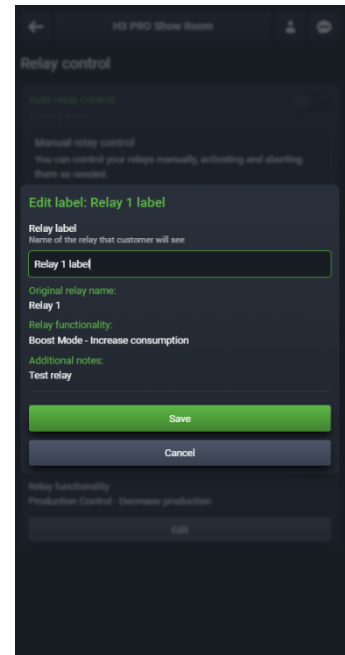
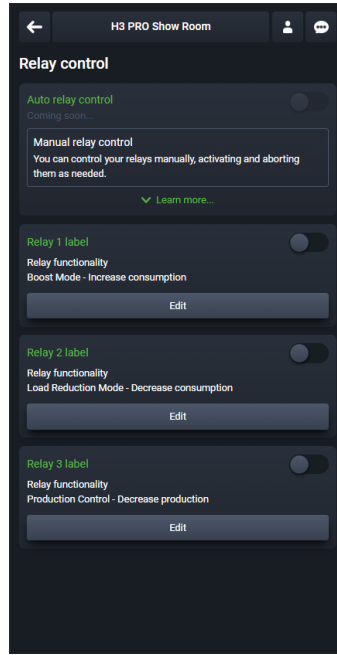

## 8. Button with LED Indicator

The button on the door of the Smart Meter TT3 is equipped with an LED indicator that visually displays the operating status of the Synaptic unit. The various colours and states of the LED have the following meanings:

- The LED light turns blue when the Synaptic unit is booting up after the power supply is switched on.
- The LED light remains solid blue when the Synaptic unit is running, and a LAN connection is established.
- The LED light flashes blue when the Synaptic unit is running via 4G, but no LAN connection is established.
- The LED light flashes red when the Synaptic unit has not internet connection via LAN or 4G.

## 9. Commissioning of the Smart Meter TT3

### 9.1. Requirements

- The Smart Meter TT3 is securely mounted
- All required wires are correctly mounted and connected
- All inspections that must be carried out in advance according to national/local installation regulations have been completed
- All required insulation and function tests have been carried out.

### 9.2. Start-up Steps

- Step 1: Turn on the "Input Grid" circuit breaker
- Step 2: Turn on the circuit breaker for the AC power supply to the communication devices

### 9.3. Commissioning the Smart Meter TT3 with the SG-Connect APP

Before you start commissioning the Smart Meter TT3, please download the "Smart Grid Connect" app from the App Store or Google Play Store:



	<p><b>Note!</b> To log in to the Smart Grid Connect app successfully, valid login credentials are required. Each installer will receive these credentials via email after successfully completing a technical product training session from NGEN. For further questions, please contact the manufacturer.</p>
---	---

Follow the steps below to commission the Smart Meter TT3 via the app:

**Step 1:** Open the SG Connect App and Add a new Device:



**Step 2:** Please select the installed Smart Meter device:

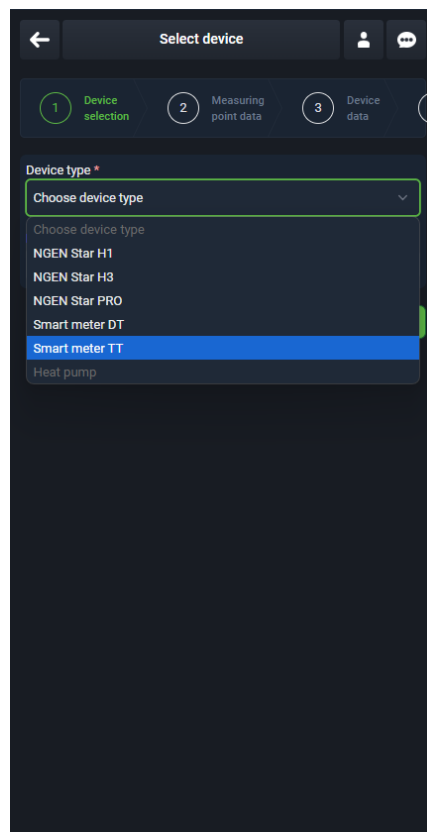

**Step 3:** Scan the QR-Code on the Synaptic-Unit to start the Commissioning process:



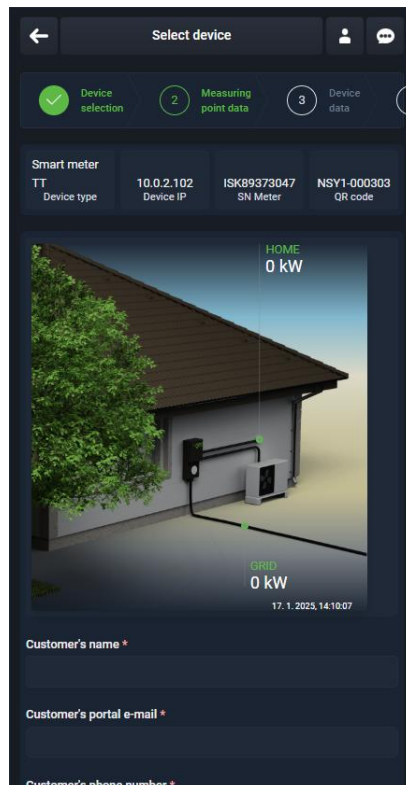

**Step 4:** Check the real-time energy flow diagram to ensure the system is operating properly:

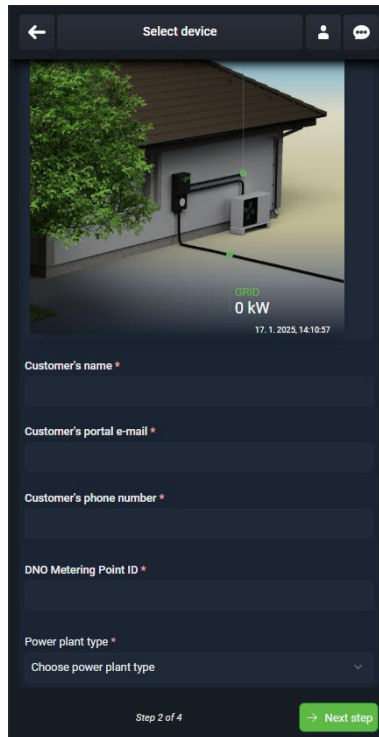

**Step 5:** Provide the following customer information:

- Customers Name
- Customers Portal E-Mail
- Customers Phone Number
- DNO Metering Point ID
- Power plant type



	<p><b>Note!</b> The customer's email address is required to enable monitoring access for the end customer. After the commissioning is completed, the end customer will receive an email from NGEN to create a password for their user account. Once the account is created, the customer can access the SG Connect app, and the system will automatically be visible.</p>
---	---

**Step 6:** Provide the customer's address information's:

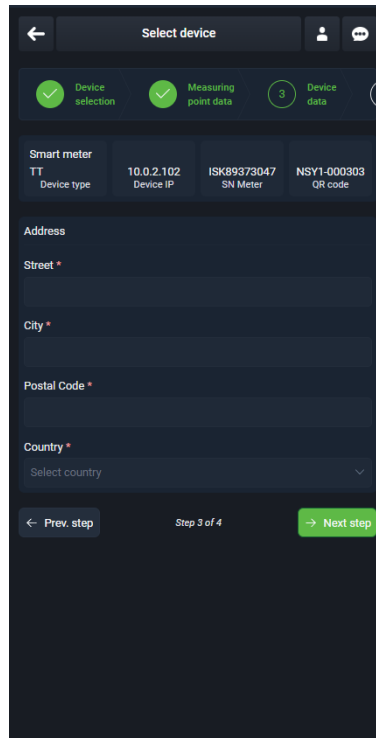

**Step 7:** Compare the live measurements from each phase in the app with the measurements of the system on-site. Additionally, please provide the required installation photos for documentation. Please confirm and sign to complete the system commissioning.

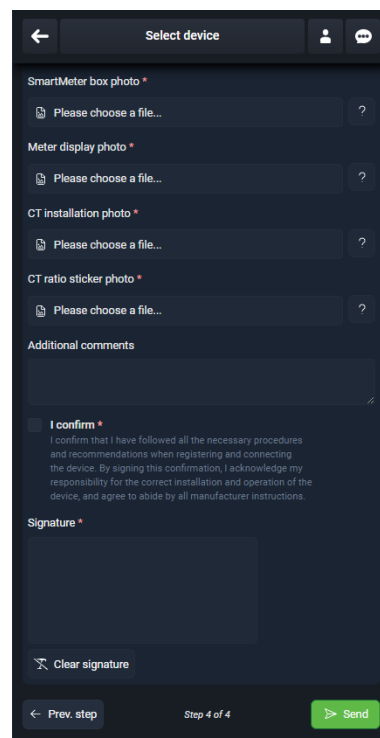
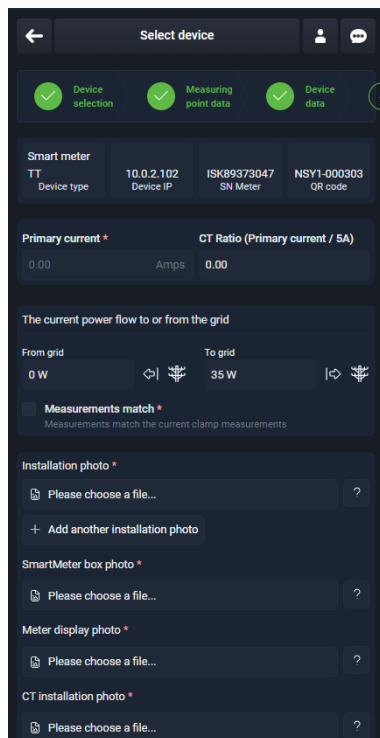

## 10. Maintenance and Cleaning

The Smart Meter TT3 should be regularly checked for functionality and safety. Please observe the national regulations, which may vary from country to country. It is recommended to have the inspection carried out by a qualified electrician **once a year**.

### 10.1. Cleaning the Smart Meter TT3

Depending on the installation location and environmental conditions, varying degrees of external contamination may occur. Clean the enclosure carefully with a damp cleaning cloth! Never open the enclosure, and only clean it with the door closed!

## 11. Storage

Requirements for the storage location:

- The storage location must be dry.
- The ambient temperature must be between -25°C and +55°C.
- Store the Smart Meter TT3 in an environment where damage due external influences can be avoided.

## 12. Disposal

Dispose of the Smart Meter TT3 in accordance with the current national and international regulations in the respective countries. The Smart Meter TT3 must not be disposed of with household waste. In the European Union, the WEEE directive governs the handling of electronic waste, which is why proper disposal is carried out at recycling or waste collection companies.

## 13. Disposal

All warranty, liability, and compensation claims for damages of any kind are excluded if they are attributable to one or more of the following causes:

- Transport damage
- Improper or non-intended use of the product
- Operation of the product in an unsuitable environment
- Operation of the product without observing the relevant legal safety regulations at the installation site
- Failure to observe the warnings and safety instructions in all product-related documentation
- Unauthorized modifications or repairs to the product
- Natural events or force majeure.

The copyright of this manual belongs to NGEN d.o.o. No legal or physical person may copy this manual, either in part or in full (including software), nor is any distribution or reproduction of the manual in any form or manner permitted. All rights reserved by NGEN d.o.o., Moste 101, 4274 Žirovnica, Slovenia. [www.NGEN.si](http://www.NGEN.si)